

# USING GYPSUM BOARD

## FOR WALLS AND CEILING (GA-201-80)

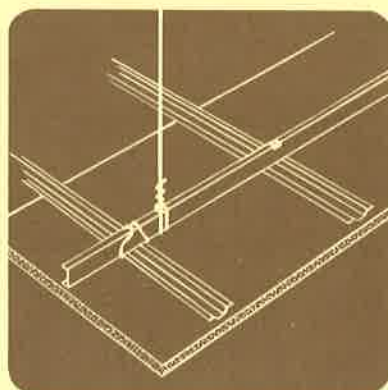
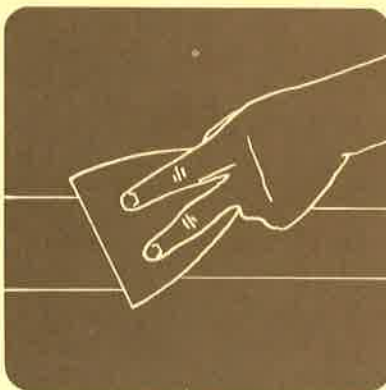
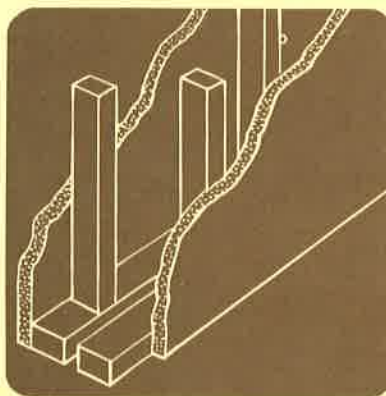

**GYPSUM  
ASSOCIATION**

1603 Orrington Avenue,  
Evanston, Illinois 60201



# USING GYPSUM BOARD FOR WALLS AND CEILINGS



**GYPSUM  
ASSOCIATION**

1603 Orrington Avenue,  
Evanston, Illinois 60201

# TABLE OF CONTENTS

## I GYPSUM BOARD CONSTRUCTION

WHAT IS GYPSUM BOARD?	1
GLOSSARY	1
ADVANTAGES OF GYPSUM BOARD CONSTRUCTION	2
Fire Resistance .....	2
Sound Isolation .....	2
Durability .....	2
Economy .....	2
Versatility .....	2
TYPES OF GYPSUM BOARD PRODUCTS	3
Regular Gypsum Board .....	3
Type X Gypsum Board .....	3
Predecorated Gypsum Board .....	4
Water-Resistant Gypsum Board .....	4
Gypsum Backing Board .....	4
Gypsum Coreboard .....	4
Gypsum Sheathing .....	4
Gypsum Board Substrate .....	4
Gypsum Form Board .....	4
Gypsum Base for Veneer Plaster .....	4
Gypsum Lath .....	4
APPLICATION OF GYPSUM BOARD	4
Single and Multi-Ply Application .....	5
Jobsite Preparations .....	6
Cutting and Fitting Procedures .....	7

## II SUPPORTING CONSTRUCTION

WOOD FRAMING	8
Furring .....	9
Studs .....	9
Joists .....	9
METAL STUD PARTITIONS AND CEILING SYSTEMS	10
Studs .....	10
Joists .....	10
METAL FURRING CHANNELS	10
Cold-Rolled Channels .....	10
Rigid Furring Channels .....	10
Resilient Furring Channels .....	11
ATTACHMENTS AND FASTENERS	11
Nails .....	11
Screws .....	12
Type W Gypsum Drywall Screws .....	12
Type S Gypsum Drywall Screws .....	12
Type G Gypsum Drywall Screws .....	12
Staples .....	12
Adhesives .....	12
Stud Adhesives .....	12
Dry Powder Laminating Adhesives .....	13
Drywall Contact and Modified Contact Adhesives .....	13
Modified Contact Adhesives .....	13
MASONRY AND CONCRETE WALLS	13

**TABLE  
OF  
CONTENTS**  
  
**(Continued)**

**III SINGLE-PLY APPLICATION**

<b>NAIL ATTACHMENT</b>	<b>15</b>
Attachment Procedures .....	15
<b>SCREW ATTACHMENT</b>	<b>16</b>
<b>FLOATING INTERIOR ANGLE CONSTRUCTION</b>	<b>16</b>
<b>ADHESIVE NAIL-ON ATTACHMENT</b>	<b>16</b>
Stud Adhesives .....	17
<b>ADHESIVE APPLICATION TO METAL FRAMING</b>	<b>18</b>
<b>CONCRETE AND MASONRY</b>	<b>18</b>

**IV MULTI-PLY APPLICATION**

<b>INSTALLATION OVER WOOD FRAMING AND FURRING</b>	<b>19</b>
Base Ply Ceilings .....	19
Base Ply Walls .....	19
<b>METAL FRAMING OR FURRING</b>	<b>20</b>
Base Ply Attachment .....	20
Face Ply Attachment .....	20
Adhesive Attachment .....	20
Supplemental Fasteners .....	21
<b>SELF-SUPPORTING GYPSUM PARTITIONS</b>	<b>21</b>
Semi-Solid Partitions .....	21
Solid Partitions .....	22
<b>PREDECORATED COMBUSTIBLE PANELING OVER GYPSUM SUBSTRATE</b>	<b>23</b>
Application .....	23
<b>RESURFACING EXISTING CONSTRUCTION</b>	<b>23</b>

**V JOINT AND FASTENER TREATMENT**

<b>JOINT TREATMENT PRODUCTS</b>	<b>24</b>
<b>JOINT TREATMENT PROCEDURE</b>	<b>25</b>
Texturing .....	25
Metal Trim and Casings .....	25
<b>PROBLEMS AND REMEDIES</b>	<b>27</b>
Nail Pops .....	27
Beading or Ridging .....	27
Shadowing .....	27
Cracking .....	27

**VI DECORATING**

<b>PREDECORATED GYPSUM BOARD</b>	<b>28</b>
----------------------------------	-----------

**TABLE  
OF  
CONTENTS**  
  
**(Continued)**

**VII SPECIAL CONSTRUCTION**

<b>SOUND INSULATION CONSTRUCTION</b>	<b>29</b>
Separated Partitions .....	29
Resilient Mounting .....	29
Walls .....	29
Ceilings .....	31
Sound Insulating Materials .....	31
<b>RIGID PLASTIC FOAM INSULATION</b>	<b>32</b>
General Procedures .....	32
Mechanical Application .....	32
Control Joints .....	33
<b>MOISTURE RESISTANT CONSTRUCTION</b>	<b>32</b>
Exterior Ceiling Soffit Construction .....	32
Bath-Shower Areas .....	33
<b>ELECTRIC RADIANT HEATING SYSTEMS</b>	<b>35</b>

Characteristics, properties or performance of materials or systems herein described are based on data obtained under controlled test conditions. The Gypsum Association and the member companies make no warranties or other representations as to their characteristics, properties or performance under any variation from such conditions in actual construction.



**GYPSUM  
ASSOCIATION**

1603 Orrington Avenue,  
Evanston, Illinois 60201

# I GYPSUM BOARD CONSTRUCTION

## WHAT IS GYPSUM BOARD?

### GLOSSARY

#### Adhesive, Contact.

Forms a strong bond after the two adhesive covered surfaces are brought together. Used to bond layers of gypsum board.

#### Adhesive, Dry Powder.

Used to laminate gypsum boards in multi-layer construction: gypsum board to gypsum studs or ribs and to sound insulating board. Not recommended for use on wood or wood fiber products.

#### Adhesive, Laminating.

Water based. Used in multilayer construction or to bond gypsum board to suitable masonry or concrete surfaces or wood fiber board. The bond develops slowly as adhesive dries.

#### Adhesive, Solvent Based.

Provides a more controlled vehicle evaporation in damp or cold weather. Can be used with foil-backed or predecorated gypsum board but must not come in contact with the vinyl surfaced gypsum board. Adequate ventilation is required and precautions must be taken to avoid sparks or fire near materials.

#### Adhesive, Stud.

Usually a solvent-base adhesive applied in 3/8 in. beads to metal or wood framing members for application of gypsum board. It will bridge minor framing irregularities.

#### Beading.

See **Ridging**.

#### Butt Joint.

Joints in which board ends (See "End") with the core exposed are butted together.

#### Corner Cracking.

Cracks occurring in the joint of inside corners between intersecting walls or at wall and ceiling intersections.

#### Corner-Floating

See **Floating Angles**.

#### Crimping.

A method of fastening corner beads in place or fixing metal studs in runners by pinching and deforming the metal using a special tool.

#### Cross Furring.

Furring members installed across, or at right angles to, framing members or runners.

#### Crown Joint.

The height above the surface formed by treating compound that has been applied over the joint of two abutting square edged gypsum boards.

#### Edge (of gypsum board).

The paper bound edge as manufactured, the length dimension of the gypsum board.

Gypsum board is the generic name for a family of panel products consisting of a non-combustible core, primarily of gypsum, with a paper surfacing covering the face, back and long edges. A typical board application is shown in figure 1.

Gypsum board is often called *drywall* or *plasterboard* and differs from products such as plywood, hardboard and fiber board because of its noncombustible core. It provides a monolithic surface when installed with joint treatment compound.

Gypsum is a mineral found in sedimentary rock formations in a crystalline form known as calcium sulfate dihydrate  $\text{Ca SO}_4 \cdot 2\text{H}_2\text{O}$ . One hundred pounds of gypsum rock contains approximately 21 pounds (or 10 quarts) of chemically combined water. Gypsum rock is mined or quarried and then crushed. The

crushed rock is heated to about 350 F, driving off three fourths of the chemically combined water in a process called calcining. The calcined gypsum (or hemihydrate)  $\text{Ca SO}_4 \cdot \frac{1}{2}\text{H}_2\text{O}$ , then is ground into a fine powder used in producing the base for gypsum plaster, wallboard and other gypsum products.

To produce gypsum board, the calcined gypsum is mixed with water and additives to form a slurry which is fed between continuous layers of paper on a board machine. As the board automatically moves down a conveyor line, the calcium sulfate recrystallizes or rehydrates, reverting to its original rock state. The paper becomes chemically and mechanically bonded to the core. The board is then cut to length and conveyed through dryers to remove any free moisture.

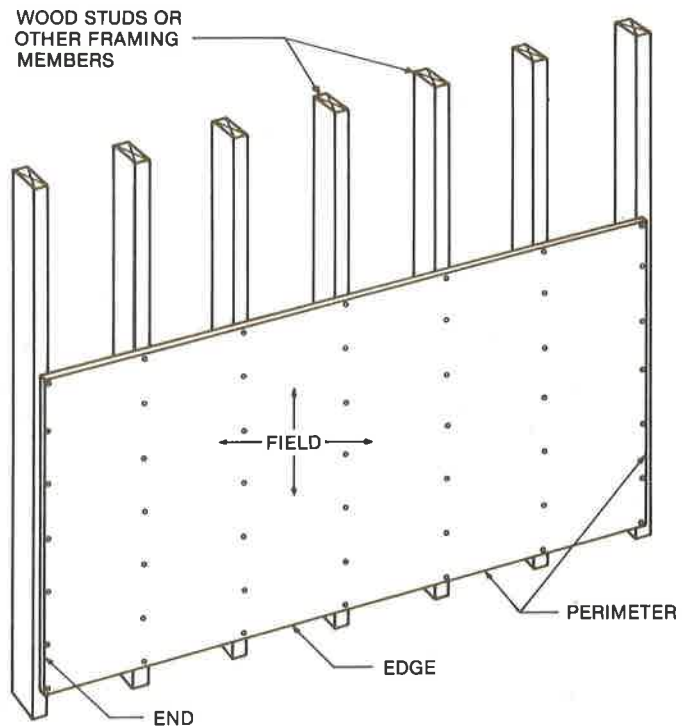

Fig. 1 Perpendicularly applied wallboards shows paper bound edges at right angles to framing members. Field, perimeter, edges, and ends are indicated.

## GLOSSARY (cont.)

### **End (of gypsum board).**

The end perpendicular to the paper bound edge. The gypsum core is always exposed.

### **Fasteners.**

Nails, screws or staples used for the mechanical attachment of the gypsum board.

### **Fastener Treatment.**

Concealing fasteners which are set below the surface of the gypsum board by successive application of joint compound until a smooth surface is achieved.

### **Feather Edging. (Feathering.)**

Tapering joint compound to a very thin edge to blend with the adjacent board surface creating a monolithic appearance.

### **Field.**

The surface of the board exclusive of the perimeter. (Fig. 1)

### **Fire Resistance Classification.**

A standard rating of fire resistive and protective characteristics of a building material or assembly when tested in conformance with requirements of ASTM Standard E 119.

### **Floating Angles.**

Mechanical fasteners on one side of interior angles are omitted to relieve stresses that might otherwise cause cracking and nail popping.

### **Framing.**

The supporting members such as studs, joists, and trusses, which may or may not bear part of the load of the building.

### **Furring.**

Wood or metal members used to provide properly spaced, rigid and even support for gypsum board. They are fastened over, or attached to, underlying construction of framing, concrete, or masonry which is not in suitable condition for direct application of gypsum board.

### **Gypsum Board.**

The name for a family of noncombustible sheet products consisting of a core primarily of gypsum between paper surfaces. The core may be regular, water resistant, special fire resistant (type X) or a combination of these. The paper surface may be treated for water resistance, or where plaster is to be applied, treated for water absorption.

### **Joint Beading.**

See **Ridging**.

### **Joint Compound.**

A material used to conceal fasteners, joints, and surface indentations in gypsum board construction.

### **Joint Treatment.**

The method of concealing gypsum board joints with tape and layers of joint compound.

### **Nail Popping.**

A protrusion of nailhead and compound directly over the nailhead caused by outward movement of the nail relative to the gypsum board due to improper nailing or shrinkage of wood framing.

### **Nails, Drywall.**

Nails designed for gypsum board application. See **Fasteners**.

### **Nail Spotting.**

See **Fastener Treatment**.

## ADVANTAGES OF GYPSUM BOARD CONSTRUCTION

Gypsum board walls and ceilings have a number of outstanding advantages:

- Fire resistance
- Sound isolation
- Durability
- Economy
- Versatility

### Fire resistance

Gypsum board is an excellent fire resistive material. It is the most commonly used interior finish where fire resistance classifications are required. Its non-combustible core contains chemically combined water which, under high heat, is slowly released as steam, effectively retarding heat transfer. Even after complete calcination, when all the water has been released, it continues to act as a heat insulating barrier. In addition, tests conducted in accordance with ASTM Method E84 show that it has low flame spread, fuel, and smoke contribution factors. When installed in combination with other materials it serves to effectively protect building elements from fire for prescribed time periods.

### Sound isolation

Control of unwanted sound that might be transmitted to adjoining rooms is a key consideration in the design stage of a building, taking into account the environment desired for the particular activity of the occupants. It has been determined that low density paneling transmits annoying amounts of noise and that sound absorbing acoustical surfacing materials, while they reduce the reflection of sound within a room, do not greatly reduce transmission of sound into adjoining rooms. Gypsum board wall and ceiling systems do effectively help control sound transmission. Suggested construction techniques for sound isolation are described and illustrated in Chapter VII along with recommended procedures and materials necessary to obtain adequate sound control.

### Durability

Gypsum board makes strong high quality walls and ceilings with excellent dimensional stability. Their surfaces are easily decorated and refinished.

### Economy

Gypsum board products are readily available and easy to apply. They are the least expensive of wall surfacing materials offering a fire-resistant interior finish. Both regular and predecorated wallboard may be installed at relatively low cost. When predecorated board is used, further decorative treatment is unnecessary.

### Versatility

Gypsum board products satisfy a wide range of architectural requirements for design. Ease of application, performance, availability, ease of repair, and its adaptability to all forms of decoration combine to make gypsum board unmatched by any other surfacing product.

## GLOSSARY (cont.)

### **Parallel Application.**

Boards are applied with their edges parallel to framing members.

### **Perimeter.**

Surface of the board at the edges and ends.

### **Perpendicular Application.**

Boards are applied with edges at right angles to framing members.

### **Ridging.**

A linear surface protrusion along with treated joints.

### **Screws, Drywall.**

Screws designed for gypsum board application. See **Fasteners**.

### **Sheet Lamination.**

Multi-ply construction with adhesives applied to the entire surface to be bonded. (See **Adhesive, Laminating.**)

### **Strip Lamination.**

Multi-ply construction with adhesive applied in parallel strips usually spaced 16 in. or 24 in. apart.

### **Sound Transmission Class (STC).**

A unit of measure used by engineers and architects to classify resistance of assemblies to airborne sound transmission.

### **Taping.**

Embedding tape in joint compound in the process of joint treatment.



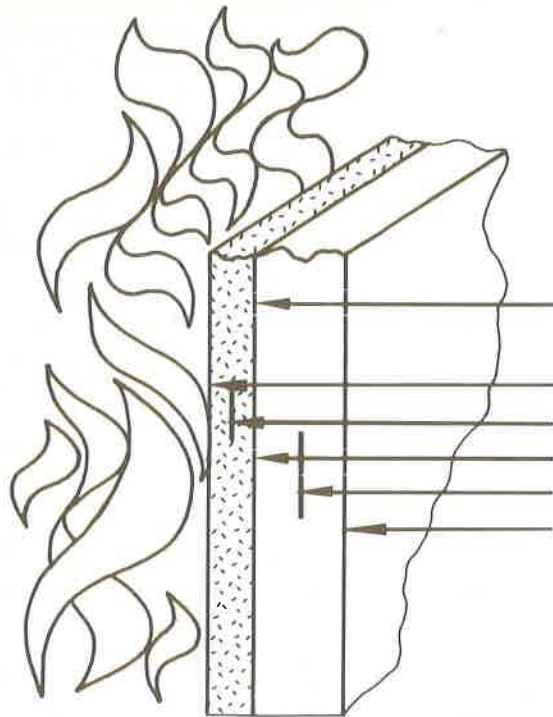

## HOW GYPSUM RETARDS HEAT TRANSMISSION

AFTER TWO HOUR EXPOSURE TO HEAT  
FOLLOWING ASTM E 119 TIME-  
TEMPERATURE CURVE

Vertical line represents plane of calcination at depth of about 2". Temperature never greatly exceeds 212 F. behind plane of calcination.

Temperature of exposed surface = 1900 F.

Temperature 1" from exposed face = 950 F.

Temperature 2" from exposed face = 220 F.

Temperature 4" from exposed face = 180 F.

Temperature at back surface = 130 F.

(Data from Underwriters' Laboratories, Inc.)

Fig. 2

## TYPES OF GYPSUM BOARD PRODUCTS

Many types of gypsum board are available for a variety of building needs. Developed through modern technology as a result of specific requirements, gypsum board panels are mainly used as the surface layer of interior walls and ceilings; as a base for ceramic, plastic and metal tile; for exterior soffits; for elevator and other shaft enclosures; and to provide fire protection to structural elements. Gypsum board products are available with aluminum foil backing which provides an effective vapor barrier for exterior walls when applied with the foil surface against the framing. With a minimum of 3/4 in. enclosed air space adjacent to the foil, additional insulating efficiency may be achieved. This combination effectively reduces outward heat flow in the cold season and inward heat flow in the warm season. (Foil backed gypsum board should not be used as a backing material for tile, a second face ply on a two-ply system, in conjunction with heating cables, or when laminating directly to masonry, ceiling and roof assemblies).

The various thicknesses of gypsum wallboard available in regular, type X and predecorated board are as follows:

- 1/4-in. —a lightweight, low cost board used as a base in a multi-layer application for improving sound control, or to cover existing walls and ceilings in remodeling.
- 5/16-in. —a lightweight gypsum board developed for use in manufactured construction, primarily mobile homes.
- 3/8-in. —a lightweight board principally applied in a double-layer system over wood framing and as a face layer in repair or remodeling.
- 1/2-in. —generally used as a single-layer wall and ceiling construction in residential work and in double-layer systems for greater sound and fire ratings.

- 5/8-in. —used in quality single-layer and double-layer wall systems. The greater thickness provides additional fire resistance, higher rigidity, and better impact resistance.

- 1-in. —either a single one inch board or two 1/2 inch factory laminated boards used as a liner or as a core-board in shaft walls, semi-solid or solid gypsum board partitions.

Standard gypsum boards are 4 ft. wide and 8, 10, 12 or 14 ft. long. The width is compatible with the standard framing of studs or joists spaced 16 in. and 24 in. o.c. (Other lengths and widths are available from the manufacturer on special order).

The standard edges are tapered, square edge, beveled, rounded, tongue and grooved, and featured joint edge. (Fig. 3)

*Regular gypsum board* is used as a surface layer on walls and ceilings.

*Type X gypsum board* is available in 1/2 in. and 5/8 in. thicknesses and has an improved fire resistance made possible

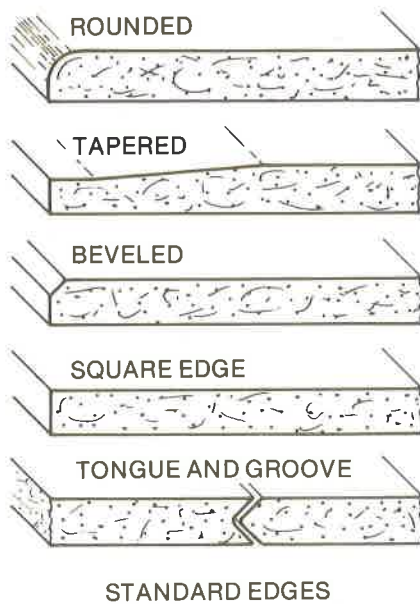

Fig. 3

through the use of special core additives. It is also available with a predecorated finish. Type X gypsum board is used in most fire rated assemblies. (Fig. 4)

*Pre-decorated gypsum board* has a decorative surface which does not require further treatment. (Fig. 5) The surfaces may be coated, printed, or have a vinyl film. Other predecorated finishes include factory painted and various textured patterns.



Fig. 4 Regular gypsum board is shown with board surface paper and both tapered and square edges. (Type X board has the same appearance)



Fig. 5 Predecorated gypsum board is available with a variety of surface finishes.

*Water-resistant gypsum board* has a water resistant gypsum core and water repellent paper. It serves as a base for application of ceramic or plastic wall tile or plastic finish panels in bath, shower, kitchen and laundry areas. It is available with a regular or type X core and in 1/2 in. and 5/8 in. thicknesses.

*Gypsum backing board* is designed to be used as a base layer or backing material in multi-layer systems. It is available with aluminum foil backing and with regular and type X cores.

*Gypsum coreboard* is available as a 1 in. thick solid coreboard or as a factory laminated board composed of two 1/2 in. boards. It is used in shaft walls and laminated gypsum partitions with additional layers of gypsum board applied to the coreboard to complete the wall assembly. It is available in 24 in. widths with a variety of edges.

*Gypsum sheathing* is used as a protective, fire resistive membrane under exterior wall surfacing materials such as wood siding, masonry veneer, stucco and shingles. It also provides protection against the passage of water and wind and adds structural rigidity to the framing system. The noncombustible core is surfaced with firmly bonded

water repellent paper. In addition, a water repellent material may be incorporated in the core. It is available in 2 ft. and 4 ft. widths, 1/2 in. and 5/8 in. thick. The latter is also available with type X core.

*Gypsum board substrate* for floor or roof assemblies has a type X core 1/2 in. thick and is available in 24 in. or 48 in. widths. It is used under combustible roof coverings to protect the structure from fires originating on the roof. It can also serve as an underlayment when applied to the top surfaces of floor joists and under sub-flooring. It may also be used as a base for built-up roofing applied over steel decks.

*Gypsum form board* has a fungus resistant paper and is used as a support and permanent form for poured-in-place reinforced gypsum concrete roof decks.

*Gypsum base for veneer plaster* is used as a base for thin coats of hard, high strength gypsum veneer plaster.

*Gypsum lath* is a board product used as a base to receive hand or machine applied plaster. It is available in a 3/8 in. or 1/2 in. thickness, 16 in. or 24 in. nominal widths, and normally 48 in. lengths. Other lengths are available on special order.

## APPLICATION OF GYPSUM BOARD

Gypsum board panels can be applied over any firm, flat base such as wood or metal framing or furring. They can be applied to masonry and concrete surfaces, either directly or to wood or metal furring strips. If the board is to be applied directly, any irregularities in the masonry or concrete surfaces must be smoothed or filled. Furring is a means to provide a flat surface for standard fastener application as well as provide separation to overcome dampness in exterior walls.

Most common in residential construction is the standard

gypsum wallboard system<sup>1</sup> with the joints between the panels and internal corners reinforced with tape and covered with joint treatment compound to prepare them for decoration. External corners are normally reinforced with corner bead which in turn is covered with joint compound. Exposed edges are covered with metal or plastic trim. The result is a smooth, unbroken surface ready for final decoration of paint, textures, wallpaper, tile,

<sup>1</sup> See "Recommended Specifications for the Application and Finishing of Gypsum Board" (GA-216)

paneling or other materials. When predecorated board is used, no further finishing is necessary, but moldings or battens can be applied to cover the joints if desired. Special instructions for installation of predecorated panels are given in Chapter VI on Decorating.

### Single and Multi-ply Application

In light commercial and in residential construction, single-ply gypsum board systems (figure 6) are commonly used. Generally, they are adequate to meet fire resistance and sound control requirements.<sup>2</sup>

Multi-ply systems (figure 7) have two or more layers of gypsum board and therefore can increase sound isolation and fire resistive performance.<sup>3</sup> They also provide better surface quality because face layers are often laminated over base layers thereby reducing the number of fasteners. As a result, surface

joints of the face layer are reinforced by the continuous base layers of gypsum board. Nail popping and ridging problems are less frequent and imperfectly aligned supports have less effect on the finished surface.

Satisfactory results can be assured with either single-ply or multi-ply assemblies by requiring proper:

- framing details (straight, correctly spaced, properly cured lumber)

- job conditions (controlled temperature and adequate ventilation during application)
- application of the board (measuring, cutting, aligning, fastening)
- joint and fastener treatment
- special requirements for proper sound isolation, fire resistance, thermal properties, or moisture resistance.

Greater details for single and multi-ply attachment are given in Chapters III and IV.

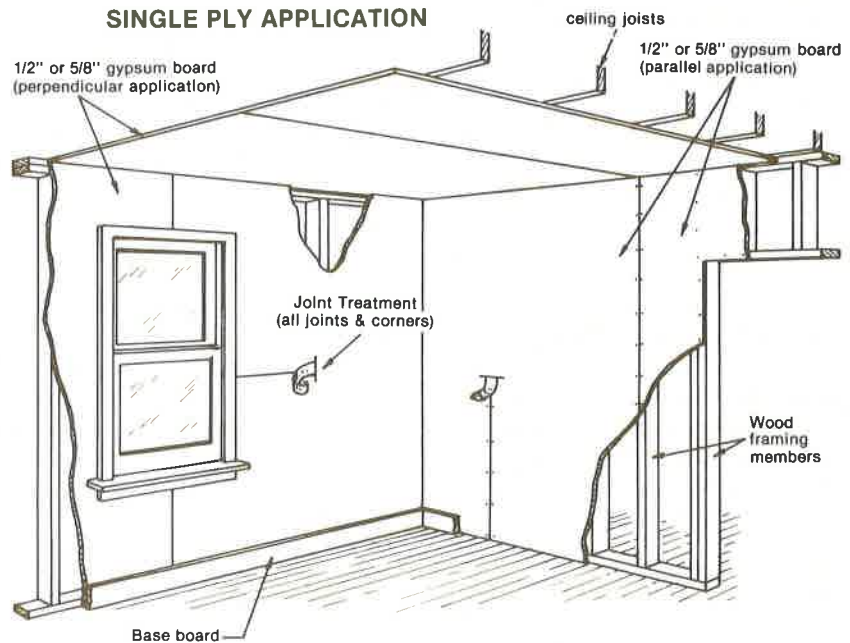

Fig. 6 Wood stud framing should provide a firm, level, plumb, and even base for single-ply gypsum board application. All joints are treated before decorating.

<sup>2</sup> Single-ply gypsum board systems achieve sound ratings from 30 to 50 STC. Fire ratings of one hour can be obtained for partitions and load bearing walls and for ceilings with some type X gypsum boards.

<sup>3</sup> Multi-ply gypsum board systems can achieve higher sound and fire ratings.

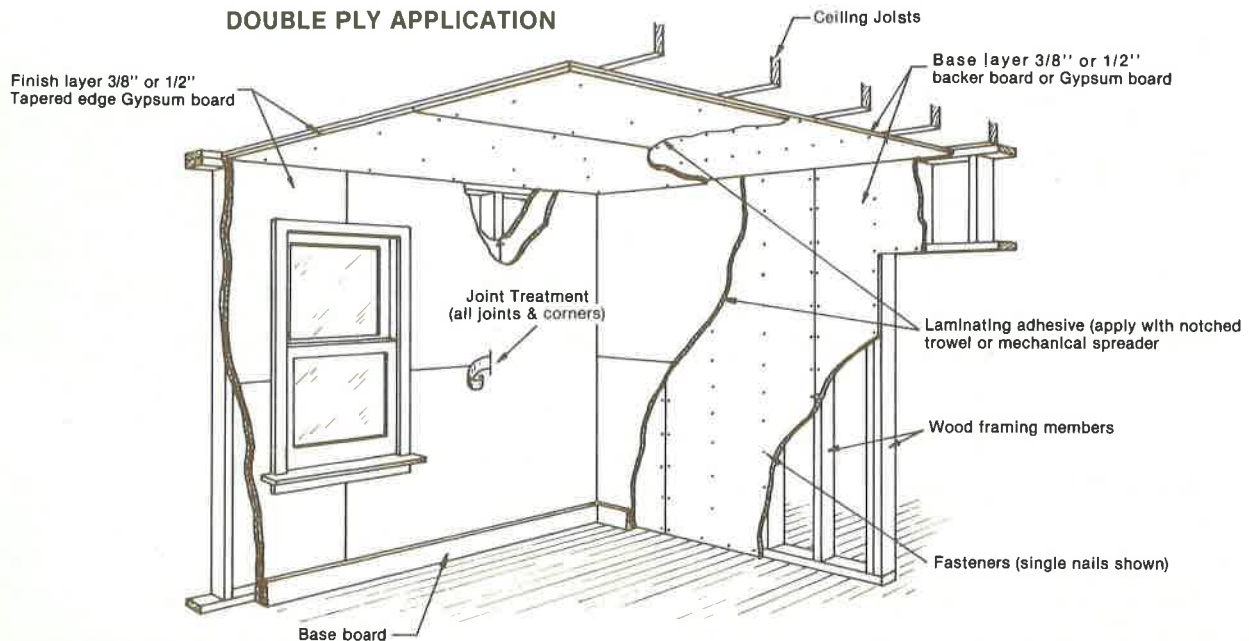

Fig. 7 Double layer multi-ply system has laminated surface layer of gypsum board and base layer of gypsum backing board for greater fire resistance, sound control and durability.

## Jobsite Preparations

Job conditions such as temperature and humidity can affect the performance of joint treatment materials and the appearance of the joint. These conditions can sometimes affect adhesive materials and their ability to develop adequate bond. During the cold season, interior finishes should not be installed unless the building has a controlled heat of not less than 50 F nor more than 80 F. These temperatures should be maintained at least 48 hours before, during, and 48 hours after, the installation. All materials should be protected from the weather.

If humidity is excessive, ventilation should be provided. In glazed buildings windows should be kept open to provide air circulation. In enclosed areas without natural ventilation, fans should be used. When drying is slow, additional drying time between coats of joint compound should be allowed. During hot dry weather, drafts should be avoided so that joint compound will not dry too rapidly.

When ceilings are to receive water-based spray texture finishes, special attention must be

given to the spacing of framing members, thickness of board used, ventilation, vapor barriers, insulation and other items which can affect the performance of the system, particularly sag of the gypsum board between framing members.

Lumber must be kept dry during storage and installation at the job site. Moisture content should not exceed 15 percent at the time of gypsum board application. "Green lumber" should not be used for framing. Since lumber shrinks across the grain as it dries it tends to expose the shanks of nails driven into the edge of the framing members, (Fig. 8). If shrinkage is substantial or nails are too long, separation between the gypsum board and its framing lumber can result in protrusion of the nail head above the board surface (nail pops).

Delivery of gypsum board should coincide with the installation schedule. Boards should be stored flat and under cover. Materials used as storage supports should be at least 4 inches in width. As the units are tiered, supports should be carefully aligned from bottom to top so that each tier rests on solid bearing.



Fig. 9 A boom truck delivers gypsum board economically to upper stories.

Stacking long lengths on short lengths should be avoided to prevent the longer boards from breaking. Leaning boards against the framing for prolonged periods with the long edges horizontal is not recommended. Leaning of boards should also be avoided during periods of high humidity as the boards may be subject to warping. All materials should remain stored in their original wrappings or containers until ready for use on the job site. When boards are moved on the job they should be carried, not dragged, so that the edges are not abused.

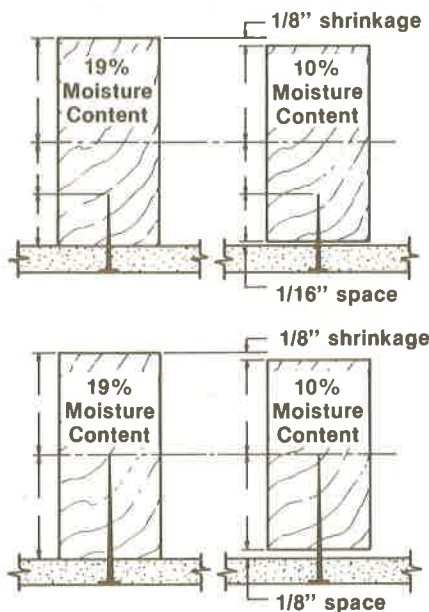

Fig. 8 Wood studs may shrink as they dry out, and separation can occur between the stud and the gypsum board in a wall. As studs shrink, separation may be as much as 1/16 in. when nails penetrate one in. or 1/8 in. with two in. penetration.

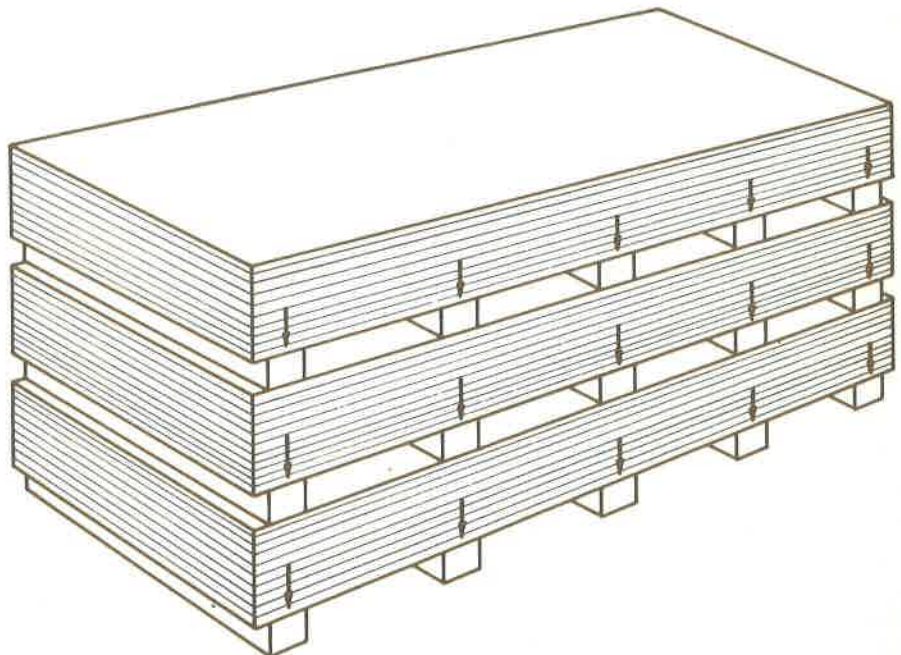

Fig. 10 Correct method of placing riser. (Arrows indicate pressure).



Fig. 11



Fig. 12

### Cutting and Fitting Procedures

Gypsum board installations should be carefully planned. Accurate measuring, cutting and fitting are very important. In residential buildings with less than 8'1" ceiling heights it is preferred that wallboard be installed at right angles to supporting members; there are usually less joints to finish. On long walls, boards of maximum practical length should be used to minimize the number of end joints. Scored, scratched, broken or otherwise damaged board should not be used.

Measurements should be taken accurately at the correct ceiling or wall location for each edge or end of the board (Figure 11). Accurate measuring will usually reveal irregularity in framing and furring so that corrective allowances can be made in cutting. Poorly aligned framing should be corrected before applying gypsum board (see Chapter II, Supporting Construction).

Gypsum board should be cut by first scoring through the paper to the core with a sharp knife, working from the face side (Figure 12). The board is then snapped back away from the cut face (Figure 13). The back paper should be broken by snapping the board in the reverse direction or by cutting the backpaper with a scoring knife. Gypsum board may also be cut by sawing. All cut edges and ends of the gypsum board should be smoothed to form neat tight-fitting joints when installed. Ragged cut ends or broken edges

can be smoothed with a rasp or sandpaper or trimmed with a sharp knife. If burrs on the cut ends are not removed they will form a visible ridge in the finished surface.

The following procedures should be followed to assure a successful application.

1. Install ceiling panels first, then the wall panels.
2. Cut panels should fit easily into place without force.
3. Match similar edges and ends, ie: tapered to tapered, square cut ends to square ends.
4. Plan to span the entire length of ceilings or walls with single boards if possible to reduce the number of end joints which are more difficult to finish. Stagger end joints and locate them as far from the center of the wall and ceiling as possible so they will be inconspicuous.
5. In a single-ply application,

the board ends and edges parallel to supporting members should fall on these members to reinforce the joint. (Exception: In a two-ply assembly, with adhesive between the plies, the ends and edges of face layers need not fall on supporting members).

Mechanical and electrical equipment should be installed to provide for the wall thickness when applying the trim components such as cover plates, registers and grilles. The depth of electrical boxes should not exceed the framing depth and boxes should not be placed back to back in the same stud cavity space. Electrical boxes, cabinets and other devices should never be allowed to penetrate completely through walls. This is detrimental to sound and fire resistance.



Fig. 13

# II SUPPORTING CONSTRUCTION

## WOOD FRAMING

All wood framing and furring must be accurately aligned in the same plane so that the gypsum board fits flat against it at all points (Fig. 14). Framing member surfaces should not vary more than 1/4 in. from the plane of the faces of adjacent supports.

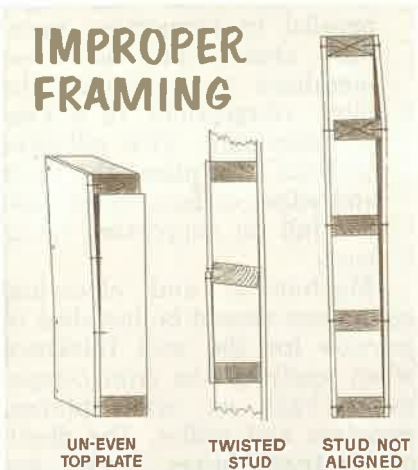

Fig. 14 Framing that is not accurately aligned can cause loose board attachment and problems in finished surfaces.

Furthermore, the spacing of framing should not exceed the maximum recommended for the gypsum board thickness as shown in Table I for single-ply and in Table II for multi-ply construction. Avoid placing and stapling paper flanges of insulation batts over framing faces, since the paper can wrinkle and cause eventual ridging and nail popping problems.

When selecting the wood for framing and furring, care should be taken to use only properly cured lumber. Excessive moisture in wood can cause warping as the wood dries. "Green lumber" should not be used. If warped or crooked studs and joists have been used, they should be replaced with straight lumber. Gypsum board cannot compensate for improper or misaligned framing.

When proper framing practices are followed, a firm, even structure for the application of

TABLES I & II					
Table I Maximum Framing Spacing					
Single-ply Gypsum Board (Thickness)	Application To Framing		Maximum o.c., Spacing of Framing		
Ceilings:					
3/8 in.	Perp.		16 in.		
1/2 in.	Perp.		16 in.		
*5/8 in.	Parl.		16 in.		
*1/2 in.	Perp.		24 in.		
5/8 in.	Perp.		24 in.		
*Only 5/8 inch thick gypsum board should be used, applied perpendicularly (horizontally), on ceilings to receive a spray applied water based texture finish.					
Sidewalls:					
3/8 in.	Perp. or Parl.		16 in.		
1/2 in. or 5/8 in.	Perp. or Parl.		24 in.		
Table II Maximum Framing Spacing Fasteners Only — No Adhesive Between Plies					
Multi-ply Gypsum Board (Thickness)	Application to Framing		Maximum o.c., Spacing of Framing		
	Base	Face	Base	Face	
Ceilings:					
3/8 in.	3/8 in.	3/8 in.	Perp.	Perp.	16 in.
1/2 in.	*3/8 in.	*3/8 in.	Parl.	Perp.	16 in.
	*1/2 in.	*1/2 in.	Parl.	Perp.	16 in.
1/2 in.	*1/2 in.	*1/2 in.	Perp.	Perp.	24 in.
5/8 in.	*1/2 in.	*1/2 in.	Perp.	Perp.	24 in.
	5/8 in.	5/8 in.	Perp.	Perp.	24 in.
*Only 5/8 in. thick gypsum board should be used for the face layer, applied perpendicularly (horizontally) on ceilings to receive a spray applied water based texture finish. 3/8 in. thick gypsum board should be increased to 1/2 in. thickness and applied perpendicular to 16 in o.c. framing.					
Sidewalls:					
For two layer application, with no adhesive between plies, 3/8 in., 1/2 in. or 5/8 in. thick gypsum board may be applied perpendicularly (horizontally) or parallel (vertically) on framing spaced a maximum of 24 in. o.c. Maximum spacing should be 16 in. o.c. when 3/8 in. thick board is used as the face layer.					

gypsum board will result. Headers or lintels should be provided over openings to support structural loads and special construction should be provided where required to support wall hung equipment and fixtures.

The bath and shower areas are examples where special framing must be provided for grab bars and heavy fixtures. Provision should also be made for cabinets or wall hung appliances in the kitchen or utility areas.

## Furring

Cross furring should be used to correct surface unevenness in the existing framing. The fastening surface of wood furring strips must be no less than 1-1/2 in. actual dimension. In general, wood furring should not be less than nominal 2 x 2 to provide a rigid support during nailing when the wood furring strips are directly attached to the underlying framing. Where wood furring strips are attached to concrete or masonry walls and where screws are used to attach the gypsum board, wood furring may be nominal 1 x 3 (3/4 in. minimum) size. The maximum spacing between furring strips should be the same as shown for framing members in Table I or Table II.

In wood framed construction where a higher degree of sound control is desired, gypsum board can be screw attached to resilient metal furring channels.

## Studs

Wood studs in load-bearing partitions usually are 2 x 4 or larger. In nonload-bearing single row stud or staggered stud partitions, 2 x 3 wood studs may be used.

Back-up or extra members should be provided at all interior corners for support or as a nailing base for the gypsum board.

## Joists

Ceiling joists should be evenly spaced with faces aligned in a level plane. Excessively bowed or crooked joists should not be used. Joists with a slight crown may be used if they are installed with the crown up. Slightly crooked or bowed joists can sometimes be aligned by nailing bracing members (strong-back) across the joists approximately at mid span (Fig. 16).

Wood trusses to which a ceiling is to be attached might have irregularities in spacing and leveling. When wide variances are found, cross furring generally is recommended to provide a level surface to support

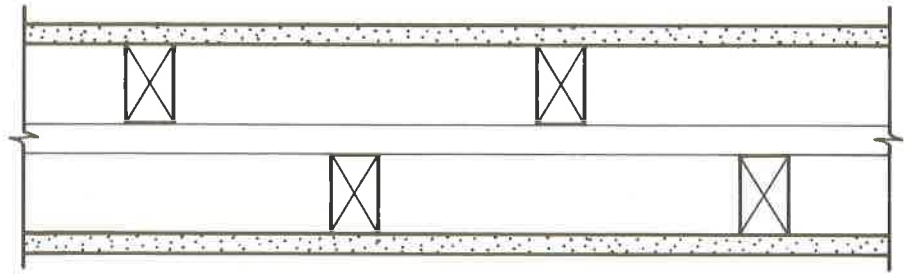

Fig. 15 Staggered stud partition.

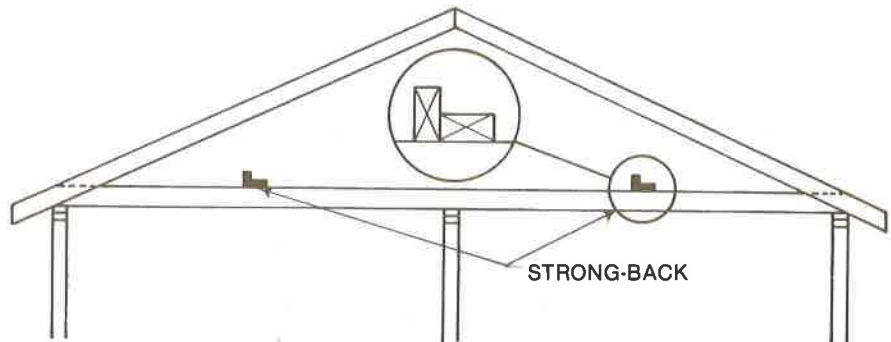

Fig. 16 Slightly crooked or bowed joists may be corrected by nailing stringers approximately at the mid spans. 2 in. x 4 in. stringers, laid flat, regulate spacing, and other stringers, set on edge, accomplish some leveling.

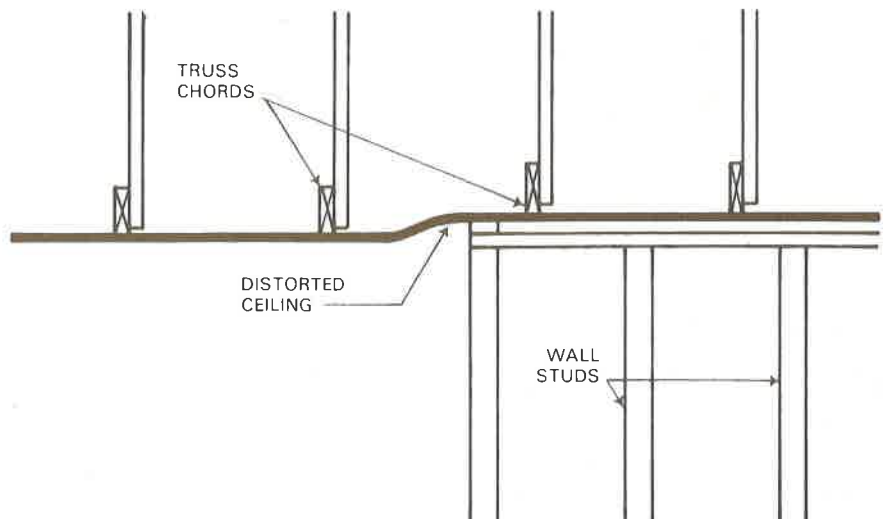

Fig. 17 Ceiling distortion can result under truss roofs where the weight of the roof forces the ceiling down and the interior partitions hold up. Partitions should be installed only after truss roofs and ceilings are completed and the roof covering is finished.

the gypsum board.

With truss roof construction, the exterior walls and ceilings often are finished before interior partitions are erected and finished. When this method is used, the roofing and all other construction elements which increase

roof loads should be installed before interior partitions are erected. If substantial roof loads are introduced after partitions are installed, the ceiling may be forced down against the partitions and may be distorted as the roof trusses deflect (Fig. 17).

## METAL STUD PARTITIONS AND CEILING SYSTEMS

The advantages of metal framing are noncombustibility, uniformity of dimension, lightness of weight, freedom from rot and moisture problems, and relative ease of erection. The components of metal frame systems are manufactured to fit together easily.

There are a variety of metal framing systems, both load bearing and non-load bearing. Some non-load bearing gypsum partition systems are designed to be demountable or movable and still meet requirements for sound isolation and fire resistance.<sup>1</sup>

Metal stud partition systems are commonly used in highrise and other buildings where non-combustible partition framing and furring are required (Fig. 18). Ceilings usually are applied to furring members secured to or suspended from open-web joists or light beams.<sup>2</sup>

The spacing for metal framing to receive gypsum board should not exceed the maximum spans recommended for single and multi-ply construction as shown in Tables I and II on page 8.

### Studs

Typically, metal studs in non-load bearing partition framing are "C" shaped, 25 gage steel, and have a protective coating to prevent corrosion in normal use. (Fig. 19) They are available 1-5/8, 2-1/2, 3-1/4, 4, 3-5/8, or 6 inches deep and from 6 ft. to 16 ft. long.<sup>3</sup>

<sup>1</sup> The Gypsum Association Fire Resistance Design Manual (GA-600) contains a wide variety of designs tested for fire resistance and sound control.

<sup>2</sup> Detailed specifications for application of gypsum board to metal framing are given in Gypsum Association Recommended Specifications for the Application and Finishing of Gypsum Board, GA-216 and in ASTM Standard C754.

<sup>3</sup> Studs should be manufactured in conformance with ASTM Standard Specification for Non-Load (Axial) Bearing Steel Studs, Runners (track), and Rigid Furring Channels for Screw Application of Gypsum Board, C 645.



Fig. 18 Metal Studs go up quickly in this office building.

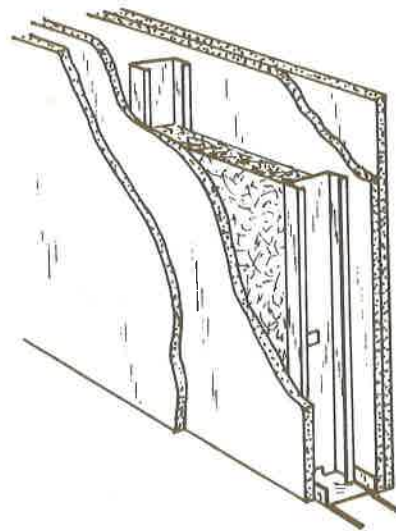

Fig. 19 "C" shaped steel studs placed in metal runners support this multi ply, sound-insulating partition.

### Joists

Open-web steel bar joists are not designed to receive wallboard directly, and they often are spaced more than 24 in. o.c. Hence, it is necessary to provide suitable furring or suspension systems with appropriate spacing for attaching the gypsum board ceiling.

### METAL FURRING CHANNELS

There are three general types of metal furring channels: (Fig. 20) cold-rolled channels for suspension systems; furring channels used to space a gypsum board away from framing members; and resilient furring channels used to reduce sound attenuation through a horizontal or vertical assembly. Steel studs may also be used as furring channels where spans over 24 inches are desired. The minimum width for the fastening face of any metal furring channel must be 1 1/4 in. to accommodate abutting edges or ends of gypsum panels.

*Cold-rolled channels* may be used in furred partitions and in most types of suspended ceiling assemblies. Ordinarily, they are suspended by wire or rods with the furring channels tied or clipped to them. These channels are usually of 16 gage steel with either a galvanized or black asphaltum finish. They are available in sizes ranging from 3/4 in. to 2 in. wide in lengths up to 20 ft.

*Rigid furring channels* are 25 gage galvanized steel and are generally "hat" shaped. Rigid





Fig. 20 Plain drywall channel (top) has a hat shaped cross section, while resilient drywall channels (center four) come in several designs. All are of galvanized steel. Cold rolled channels (bottom two) are "C" shaped and generally of 16 gauge black asphaltum painted steel.

furring channels are designed for gypsum board attachment with gypsum drywall screws described on page 12. The furring channels should be installed at right angles to the furring supports. They are fastened to wood framing with  $1\frac{1}{4}$  in. long screws or  $1\frac{3}{4}$  in. 5d nails, and to metal framing with screws, wire ties or clips.

Rigid furring channels over masonry or concrete surfaces may be installed horizontally or vertically. Metal studs may be used in place of furring channels. The spacing should be as shown in Table I or Table II on page 8.

*Resilient furring channels* are used over both metal and wood framing to provide a sound absorbent spring mounting for gypsum board and should be attached as specified by the manufacturer. They not only improve sound isolation, but

they also help to isolate the gypsum board from structural movement, minimizing the possibility of cracking. Resilient furring channels may also be used for the application of gypsum board over masonry or concrete walls. (Fig. 21)

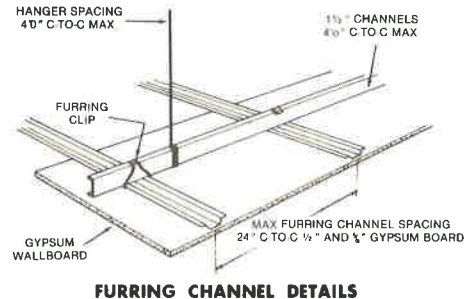

Fig. 21 In suspended gypsum board ceilings, drywall channels are clipped to suspended cold rolled channels rather than to framing members. Various clips are used.

## ATTACHMENTS AND FASTENERS

Nails and screws are commonly used to attach gypsum board in both single and multiply installations; clips and staples are used only to attach the base layer in multi-ply construction.

Special drywall adhesives can be used to secure single-ply gypsum board to framing and furring, masonry and concrete, or to laminate a face ply to a base layer of gypsum board or other base material. Adhesives must be supplemented with mechanical fasteners.

Mechanical application of gypsum board requires special fasteners. Ordinary wood or sheet metal screws and common nails are not designed to penetrate the board without damage, hold it tightly against framing or permit correct countersinking for proper fastener concealment.

Where fasteners are used at the board perimeter, they should be placed at least  $\frac{3}{8}$  in. from board edges and ends. Fastening should start in the middle of the board and proceed outward toward the perimeter. Fasteners should be driven as near to perpendicular as possible while the board is held firmly against the supporting construction. Nails should be driven with a crown-headed hammer which forms a uniform depression or "dimple" not more than  $\frac{1}{32}$  in. deep around the nail head (Fig. 22). Particular care should be taken not to break the face paper or crush the core with too heavy a blow.

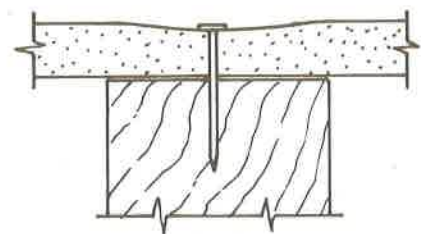

Fig. 22

### Nails

Examples of acceptable nails for gypsumboard application are shown in Fig. 23. Preferably, the nails should have heads that are flat or concave and thin at the rim. The heads should be at least  $\frac{1}{4}$  in. in diameter and less than  $\frac{5}{16}$  in. in diameter to provide adequate holding power without cutting the face paper when the nail is dimpled. Casing nails and common nails have heads too small in relation to the shank; they easily cut into the face paper and should not be used. Nail heads that are too large are also likely to cut the paper surface if the nail is driven incorrectly at a slight angle.

Nails should be long enough to go through the wallboard layers and far enough into supporting construction to provide adequate holding power. Nail penetration into the framing member should be  $\frac{7}{8}$  in. for smooth shank nails, but only  $\frac{3}{4}$  in. for annular ringed nails which provide more withdrawal resistance and require less penetration. For fire rated assemblies, greater penetration is required; generally 1- $\frac{1}{8}$  in. to 1- $\frac{1}{4}$  in. for one hour assemblies.



Fig. 23 Nails used in drywall construction have thin, 1/4 in. diameter heads. Small-headed nails shown are colored for use with predecorated wallboard. These are used according to instructions of the manufacturers.

### Screws

Drywall screws are used to attach gypsum board to wood or steel framing or to other gypsum boards. They have cupped Phillips heads designed for use with a drywall power screwdriver. These screws pull the board tightly to the supports without damaging the board, and minimize fastener and surface defects due to loose boards. The specially contoured head when properly driven makes a uniform depression free of ragged edges and fuzz.

The three basic types of drywall screws, Type W for wood, Type S for sheetmetal, and Type G for solid gypsum construction, are shown in Fig. 24. Also shown are Type S-12 screws for attaching wallboard to heavier gage, load-bearing metal studs.

*Type W gypsum drywall screws* are designed for fastening gypsum board to wood framing or furring. Diamond-shaped points on Type W screws provide efficient drilling action through both gypsum and wood, and a specially designed thread gives quick penetration and increased holding power. Recommended minimum penetration into supporting construction is 5/8 in. However, in two-ply construction where the face layer is screw attached, additional holding power is developed in the base ply which permits reduced penetration into supports to 1/2 in. Type S screws, may be substi-

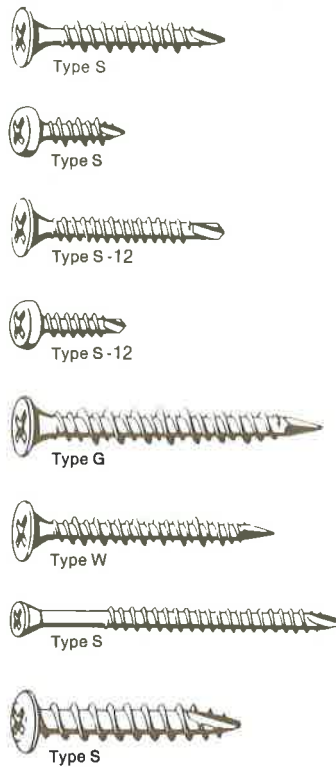

Fig. 24 Type S screws shown should penetrate at least 3/8 in. beyond gypsum board surface to hold tightly against metal framing. Type G screws should penetrate at least 3/8 in. into supporting layers of gypsum board to hold tightly, and Type W screws should penetrate at least 5/8 in. into wood framing under gypsum board.

tuted for Type W in two-ply construction.

*Type S gypsum drywall screws* are designed for fastening gypsum board to metal studs or furring. They are self-drilling, have a self-tapping thread and generally a mill-slot or hardened drill point designed to penetrate sheet metal with little pressure. (Easy penetration is important because steel studs often are flexible and tend to bend away from the screws.)

*Type G gypsum drywall screws* are used for fastening gypsum board panels to gypsum backing boards. Type G are similar to Type W screws, but they have a deeper special thread design. They are generally 1-1/2 in. long, but other lengths are available. Gypsum drywall screws require penetration of at least 1/2 in. of the threaded portion into the supporting board. Allowing approximately 1/4 in. for the point results in the minimum penetration of 3/4 in.

Gypsum drywall screws should not be used to attach wallboard to 3/8 in. backing board because sufficient holding strength is not available. Nails or longer screws should be driven through both the surface layer and the 3/8 in. base ply to give the proper penetration in supporting wood or metal construction.

### Staples

Staples are recommended only for attaching base ply to wood members in multi-ply construction. They should be 16 gauge, flattened, galvanized wire with a minimum 7/16 in. wide crown and spreading points. Staples should provide a minimum of 5/8 in. penetration into supports.

### Adhesives

Adhesives are used to bond single layers of gypsum board directly to framing, furring, masonry, or concrete. They can also be used to laminate gypsum board to base layers of backing board, sound deadening board, rigid foam, or other rigid insulation boards. They must be used in combination with nails or screws which provide supplemental support. Adhesives for applying wallboard finishes are classed:

1. stud adhesives
2. laminating adhesives;
  - a. dry powder (including joint taping compound)
  - b. special drywall laminating adhesives
  - c. drywall contact and modified contact adhesives

*Stud adhesives* are specially prepared to attach single-ply wallboard to steel or wood supports and generally are used in conjunction with adhesive nail-on application. Some permit even further reduction in mechanical fasteners, but these also require fastening at least at the board perimeters. They should be of caulking consistency so that they bridge framing irregularities. Also they should meet the requirements of the Standard Specification for Adhesives for Fastening Gypsum Wallboard to Wood Framing (ASTM Designa-

tion: C557) for workability, consistency, open time, wetting characteristics, strength, bridging ability, aging and freeze-thaw resistance. They are applied with a gun (Fig. 25) in a continuous or semi-continuous bead. If the stud adhesive has a solvent base it should not be used near an open flame, in poorly ventilated areas, or for lamination of predecorated gypsum board. Special adhesives are available for predecorated gypsum board.



Fig. 25 Application with a stud adhesive gun.

*Dry powder laminating adhesives* generally are gypsum dry-wall joint compounds used to embed joint reinforcing tape. They are used to laminate gypsum boards to each other or to suitable masonry or concrete surfaces. They are not intended for adhesive bonding to wood framing or furring. Although special laminating adhesives as well as some stud and contact adhesives also can be used for laminating, they should only be used when recommended by the manufacturer.

Only as much laminating adhesive should be mixed as can be used within the working time specified by the manufacturer. Water used should be at room temperature, clean enough to drink. The adhesive may be

applied over the entire board area with a suitable spreader, or it may be applied in spaced parallel ribbons or a pattern of spots as recommended by the manufacturer. All dry powder laminating adhesives require permanent mechanical fasteners at the perimeter of the boards. If the board is applied vertically on sidewalls, fasteners are placed at the top and bottom. Face boards may require temporary support or supplemental fasteners until full bond strength is developed.

*Drywall Contact and Modified Contact Adhesives:* These adhesives require permanent mechanical fasteners at least at the perimeter of boards applied to walls, ceilings and soffits. If used to apply predecorated gypsum wallboard vertically on sidewalls, permanent mechanical fasteners are required only at the top and bottom of the boards where they will be concealed by base and ceiling moldings or other decorative trim. Contact adhesives may be used to laminate gypsum boards to each other or to metal studs. The adhesive is applied by roller, spray gun, or brush, in a thin, uniform coating to both surfaces to be bonded. For most contact adhesives, some drying time usually is required before surfaces can be joined and bond can be developed. To assure proper adhesion between mating surfaces, the face board should be impacted over its entire

surface with a suitable tool, such as a rubber mallet. No temporary supports are needed while a contact adhesive sets and the bond forms. One disadvantage of contact adhesives is their inability to fill in irregularities between surfaces, which leaves areas without adhesive bond. Another disadvantage is that most of these adhesives do not permit moving the boards once contact has been made. A sheet of polyethylene film or tough building paper can be slipped between the surfaces so that gradual bonding of surfaces will occur as the slip sheet is withdrawn.

Extra care and judgment should be taken when contact adhesives are used. Manufacturer's recommendations should be followed.

*Modified contact adhesives* provide a longer placement time. They have an open time of up to 1/2 hour during which the board can be repositioned if necessary. They combine good long-term strength with sufficient immediate bond to permit erection with a minimum of temporary fasteners. In addition, the adhesive has bridging ability.

Modified contact adhesive is intended for attaching wallboard to all kinds of supporting construction, including solid walls, other gypsum board, and various insulating boards, including rigid foam insulation.

## MASONRY AND CONCRETE WALLS

Gypsum board panels can be laminated directly to above grade interior masonry and concrete wall surfaces if the surface is dry, smooth, clean and flat. Gypsum board can be laminated directly to exterior cavity walls if the cavities are properly insulated to prevent condensation and the inside face of the cavity is properly water proofed. Predecorated gypsum board with a surface highly resistant to water vapor should not be laminated directly to concrete or masonry since moisture may become trapped within the gypsum core of the board.

The base surface must be

made as level as possible. Rough or protruding edges and excess joint mortar should be removed and depressions filled with mortar to make the wall surface level.

Base surfaces should be cleaned of form oils, curing compounds, loose particles, dust, or grease to assure adequate bond. Concrete should be allowed to cure for at least 28 days before gypsum board is laminated directly to it.

Exterior below-grade walls or surfaces should be furred and protected with the installation of a vapor barrier and insulation in order to provide a suitable base

for attaching the gypsum board. This is also true for any surface which cannot be prepared readily for direct adhesive lamination.

Supplemental mechanical fasteners spaced 16 in. o.c. may be used to hold gypsum board in place while adhesive is developing bond.

A variety of clips, runners and adjustable brackets is available with furring systems to facilitate installation over irregular masonry walls. (Fig. 26) When special clips are used the manufacturer's instructions for their use should be followed.

**ceiling attachments**

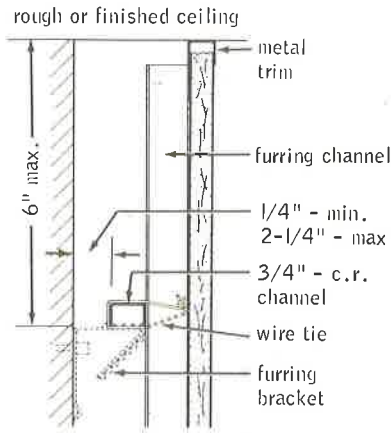

**adjustable wall furring**

**floor attachments**

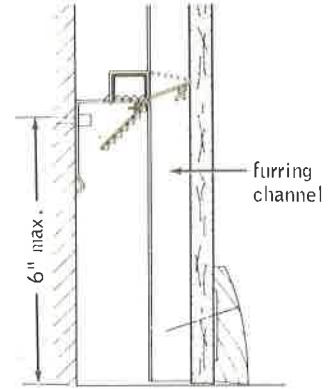

**adjustable wall furring**

Fig. 26 Adjustable brackets make installation of furring easy over irregular masonry walls.

### III SINGLE-PLY APPLICATION

The quality of single-ply surfaces is dependent on accurately aligned framing supports as described in Chapter II. Before a single-ply application of gypsum board is made, the framing or furring members should be checked for firmness and alignment (Fig. 14). Gypsum board is generally attached to framing through the use of nails, screws, and staples. Nails are most commonly used; however screws

are often used in lieu of nails in wood construction because they are applied with automatic screw guns. Screws need less penetration distance into the framing because of their thread design. Staples are used because they are economical and can be quickly applied with staple guns; however, their application is limited to the base-ply of multiplies over wood framing.

3. Hold board firmly against framing when nailing to avoid nail pops or protrusions.
4. Drive nails straight into the member. Nails that miss the supports should be removed, the nail hole dimpled, and then covered with joint compound.
5. Damage to the board caused by over driving nails is corrected by driving a new nail 2 in. away to provide firm attachment. Damage to the board should be repaired with joint treatment compound.

#### NAIL ATTACHMENT

Gypsum board can be attached by either a single-nailing or double-nailing method. Double-nailing produces a tighter board-to-stud contact. Wherever fire resistive construction is required, nail spacing specified in the fire test should be followed.

Single nails should be spaced a maximum of 7 in. o.c. on ceilings and 8 in. o.c. on walls along framing supports (Fig. 27)<sup>1</sup>. Nails are first driven in the center or field of the board and then outward toward the edges and ends. In single-ply installation, all ends and edges of gypsum board are placed over framing members or other solid backing except where treated joints are at right angles to framing members.

In double-nailing, the spacing of the first set of nails is 12 in. o.c. with the second nailing 2 in. to 2-1/2 in. from the first. (Fig. 28) The second set of nails is applied in the same sequence as the first set, but not on the perimeter of the board. The first nails driven should be repeated as necessary following application of the second set.

#### Attachment Procedures

1. Carefully measure and cut the board.
2. Prior to nailing, mark the gypsum board to indicate the location of the framing

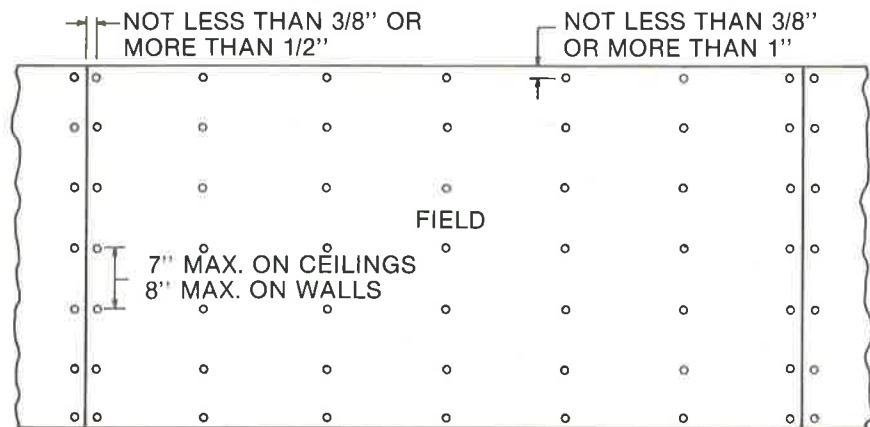

Fig. 27 In single nailed gypsum board, nails are spread 7 to 8 in. apart along supports and not less than 3/8 in. from edges and ends. Nails are first driven in the middle area of the board and then out toward the edges and ends.

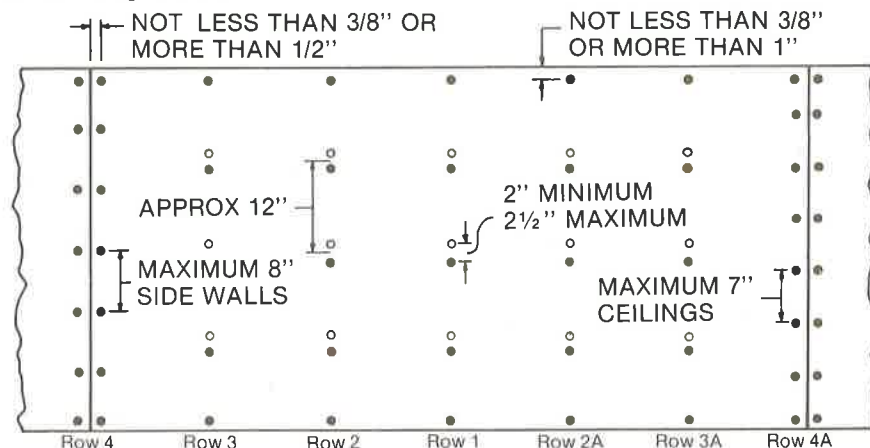

Fig. 28 In double nailing, first nails, represented by black dots, are driven starting with row 1, then row 2 and 2A, working toward the ends. Second nails, represented by the circles, are then driven in the same sequence.

<sup>1</sup> For fire and sound rated construction, framing and fastener size and spacing must follow that of the system tested. Refer to Gypsum Association Fire Resistance Design Manual (GA 600) for details of fire resistive construction.

bracing. (Fig. 14). These framing faults prevent solid contact between gypsum board and supporting members, and hammer impact causes the board to rebound and rupture the paper. Defective supports should be corrected prior to application of gypsum board. Protruding supporting members should be trimmed or reinstalled. Shims can be used if necessary for receding members. The use of screws, adhesives or two-ply construction will minimize problems resulting from these defects.

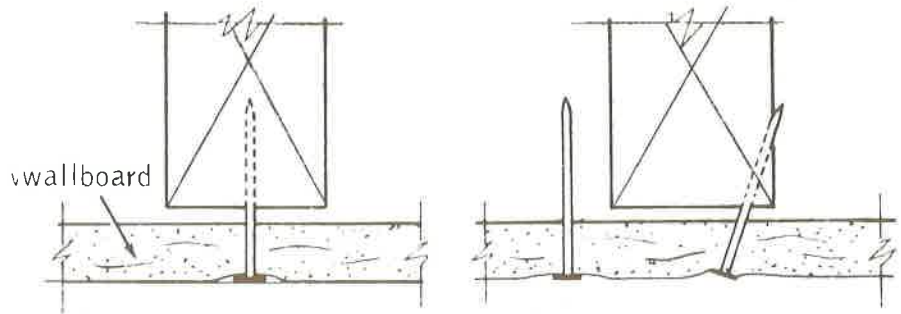

Fig. 29 Loose nails are caused by poor fit of gypsum board to framing surface (left) or by nails missing the framing members when driven (right).

## SCREW ATTACHMENT

Because fewer fasteners are required when screws are used to attach gypsum board, the number to be treated is reduced and possible application defects minimized.

Screws should be spaced 12 in. o.c. on ceilings and 16 in. o.c. on walls where framing members are 16 in. o.c. Screws should be spaced a maximum of 12 in. o.c. on walls and ceilings where framing members are 24 in. o.c. The necessary penetration for

screws is given in Fig. 24.

Gypsum board should be attached to metal framing and furring with Type S screws spaced not more than 12 in. o.c. along supports for both walls and ceilings. Type S-12 screws are required for metal framing 20 gage or heavier. These screw spacings are appropriate also when gypsum board is mounted on resilient furring channels over wood framing.<sup>2</sup>

## FLOATING INTERIOR ANGLE CONSTRUCTION

To minimize the possibility of fastener-popping in areas adjacent to the wall and ceiling intersection, and to minimize cracking due to structural stresses, the floating angle method may be used for either single or double layer application of gypsum board to wood framing. This method is applicable for single nailing, double nailing or screw attachment. The same nail-free clearances at corners should be maintained in double nailing. See figure 31.

In floating interior angle construction where the ceiling framing members are perpendicular to the wall/ceiling intersection, the ceiling fasteners should be located 7 in. from the intersection for single nailing and 11 to 12 in. for double nailing

or screw application. On ceilings, where the joists are parallel to the intersection with a wall, nailing should start at the intersection. Gypsum board should be applied to ceilings first and then to walls.

Gypsum board on sidewalls should be applied to provide a firm, level support for the floating edges of the ceiling board. The top attachment into each stud should be located 8 in. down from the ceiling intersection for single nailing, and 11 to 12 in. for double nailing or screw applications, (Figures 32a and 32b) At vertical angles, (Figure 32c)

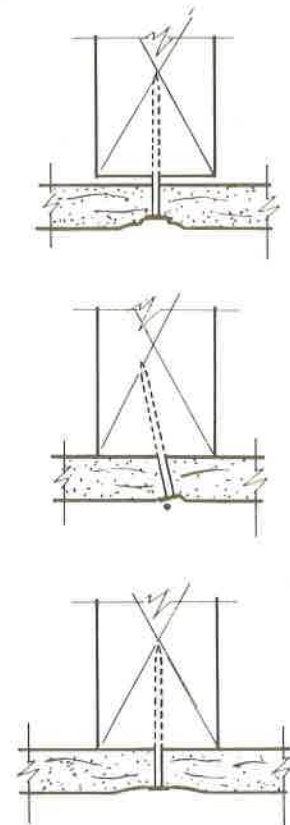

Fig. 30 Nails driven in loose board will probably fracture the face paper (top). Nails driven at an angle also usually fracture the face paper (center). Properly driven nails produce tight attachment with a slight, uniform dimple (bottom).

apply the overlapping board firmly against the underlying board to bring the underlying board into firm contact with the face of the framing member behind it. The overlapping board should be nailed or screwed and fasteners omitted from the underlying board at the vertical intersection.

## ADHESIVE NAIL-ON ATTACHMENT

An adhesive nail-on system has been developed for the application of gypsum board to

wood framing. The advantages of this system are that the number of nails can be reduced

<sup>2</sup> See footnote page 15.

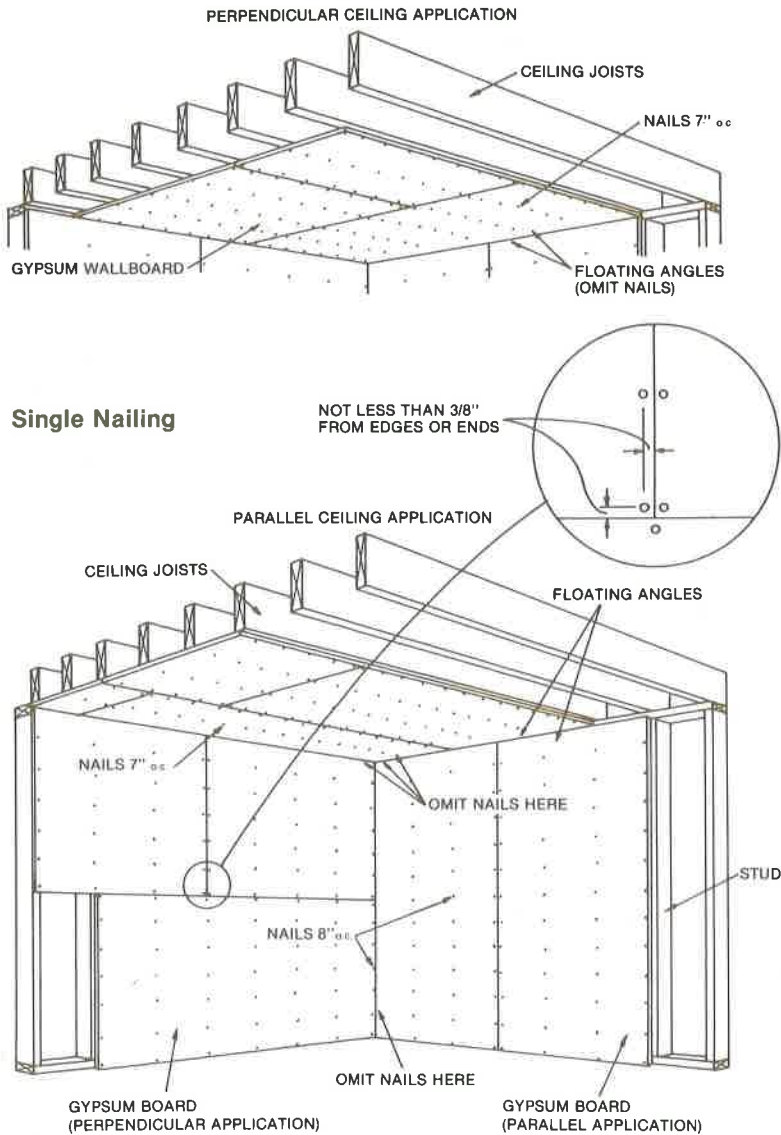

Fig. 31 Floating angle construction helps eliminate nail popping and corner cracking. Fasteners at the intersection of walls or ceilings are omitted.

by 50 percent, a continuous bond between the gypsum board and the framing is provided, and a stronger assembly with fewer fasteners is the result. The adhesive also serves to bridge minor framing irregularities. Increases in tensile strength up to 100 percent and in shear strength up to 50 percent can be achieved by this method.

### Stud Adhesives

Stud adhesives should be applied with a caulking gun in accordance with the manufacturer's recommendations. A straight bead, approximately 1/4 in. diameter, is applied to the face of supports in the field of the panel (Fig. 33). Where two gypsum panels abut over a supporting member, two parallel

beads of adhesive should be applied, one near each edge of the member. The adhesive should not squeeze out at the joints. Zig-zag or serpentine beads should be avoided under abutting boards because the adhesive can be forced out at the joint when boards are pressed tightly to the framing.

In the adhesive application of gypsum board to wall framing, supplemental fasteners are used in the perimeter of the board. The fasteners should be spaced 16 in. o.c. along edges or ends that fall on parallel supports, and at each point where edges or ends cross perpendicular supports. For ceiling application, supplemental fasteners are required in the perimeter of the gypsum board (the same as for walls) and in the field 24 in. o.c.

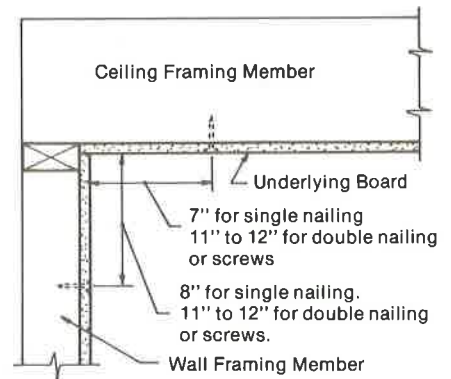

Fig. 32a Vertical section, ceiling framing member perpendicular to wall.

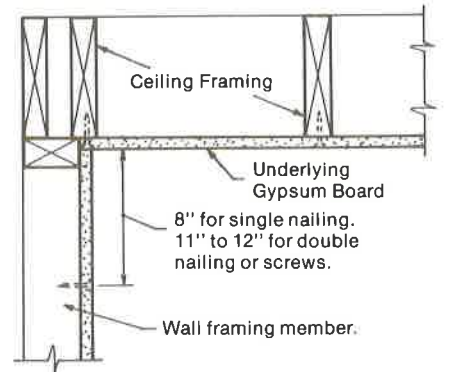

Fig. 32b Vertical section, ceiling framing parallel to wall.

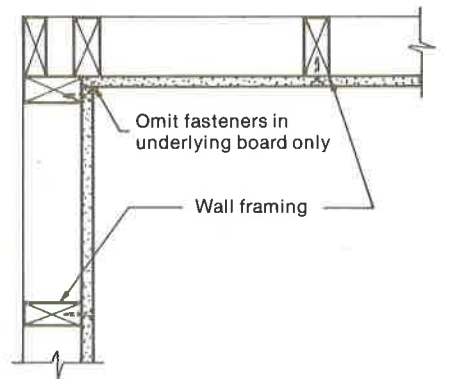

Fig. 32c Cross section through interior vertical angle.

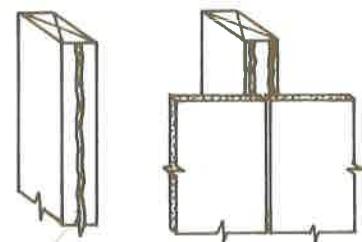

Fig. 33 Beads of stud adhesive are applied (left) straight under the field of a board, and (right) parallel under predecorated joints; or joints to be taped.

(Fig. 34). Adhesive is not required at inside corners, top or bottom plates, bridging, bracing or fire stops.

Where fasteners at vertical joints are undesirable, gypsum panels may be prebowed (Fig. 35) and adhesively attached to the framing. Supplemental fasteners 16 in. o.c. are then used at the top and bottom plates. Prebow gypsum board by stacking face up with ends resting on 2 x 4 lumber or other blocks and with center of boards resting on floor. Allow to remain overnight or until boards have a 2 in. permanent bow. Predecorated panels can be installed in this manner but care should be taken to avoid adhesive contact to the decorated face. Position within the open time specified for the adhesive and use a rubber mallet to tap the gypsum board along the studs to assure continuous bond of the board to the framing. Follow the manufacturer's specifications for predecorated gypsum board.

### ADHESIVE APPLICATION TO METAL FRAMING

Some stud adhesives, such as those used with metal framing, require fasteners on intermediate supports as well as at the perimeter of gypsum panels. Fastener spacing varies<sup>3</sup> according to type of fastener, support spacing and load bearing condition as shown in Table III.

### CONCRETE AND MASONRY

Laminating and stud adhesives are suitable for attaching gypsum board directly to concrete and masonry; however, manufacturers' recommendations can vary and should be reviewed to ensure proper selection and application. Supplemental fastening, bracing or shoring is required while the adhesive develops bond strength.

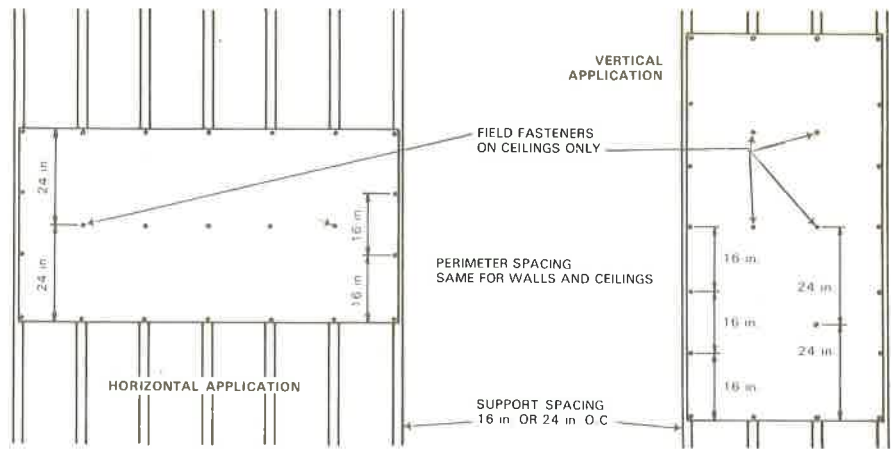

Fig. 34 Single-ply gypsum board systems attached with studs adhesives require supplemental fasteners on the perimeter. Spacing is the same whether board edges are perpendicular or parallel to supports. Ceiling installations require supplemental fasteners in the field as well as on the perimeter.

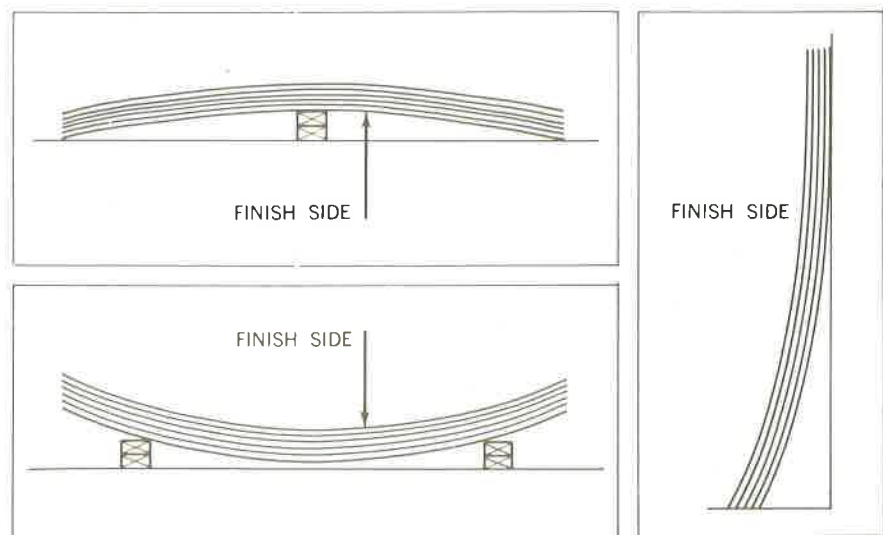

Fig. 35 Prebowing puts an arc in gypsum board that keeps it in tight contact with adhesives after it is applied.

**Table III**  
**Maximum Framing Spacing Fasteners with Adhesive Between Plies**

Gypsum Board (Thickness)	Application to Framing		Maximum o.c., Spacing of Framing	
	Base	Face		
<b>Ceilings:</b>				
*3/8 in.	3/8 in.	Perp.	Perp. or Parl.	16 in.
*1/2 in.	3/8 in. or 1/2 in.	Perp. or Parl.	Perp. or Parl.	16 in.
*5/8 in.	1/2 in.	Parl.	Perp. or Parl.	16 in.
*5/8 in.	5/8 in.	Perp. or Parl.	Perp. or Parl.	24 in.

\*Adhesive between plies should be dried or cured prior to any decorative treatment. This is especially important when spray applied water based texture finish is to be used.

Sidewalls:

For two layer application, with adhesive between plies, 3/8 in., 1/2 in. or 5/8 in. thick gypsum board may be applied perpendicularly (horizontally) or parallel (vertically) on framing spaced a maximum of 24 in. o.c.

<sup>3</sup> See footnote, page 15.



## IV MULTI-PLY APPLICATION

Multi-ply construction has one or more layers of gypsum board applied over a base layer. This results in improved surface finish, greater strength and higher fire resistance and sound classifications. The base layer

can be a gypsum backing board, with or without foil, regular gypsum board or other base material.

The maximum support spacing for multi-ply systems depends mainly upon the base-ply thick-

ness and placement. Framing spacing for wood and metal framing or furring is given in Tables I and II on page 8. Table IV on this page shows fastener spacing for the base-ply attachment.

**TABLE IV**  
**BASE-PLY FASTENER SPACING <sup>1</sup>**

Location	NAIL SPACING		SCREW SPACING		STAPLE SPACING	
	Laminated Face Ply	Nailed Face Ply <sup>3</sup>	Laminated Face Ply <sup>2</sup>	Screwed Face Ply <sup>3</sup>	Laminated Face Ply	Nailed or Screwed Face Ply <sup>3</sup>
Walls	8 in. o.c.	16 in. o.c.	16 in. o.c.	24 in. o.c.	7 in. o.c.	16 in. o.c.
Ceilings	7 in. o.c.	16 in. o.c.	16 in. o.c.	24 in. o.c.	7 in. o.c.	16 in. o.c.

<sup>1</sup> Fastener size and spacing for applying sound deadening boards vary for different fire and sound rated constructions. The manufacturer's recommendations should be followed.

<sup>2</sup> 12 in. o.c. for both ceilings and walls when supports are spaced 24 in. o.c.

<sup>3</sup> Fastener spacing for face ply shall be the same as for single layer application.

## INSTALLATION OVER WOOD FRAMING AND FURRING

### Base ply ceilings

When a multi-ply system with a laminated face ply is to be used over wood supports, the base ply should be fastened as recommended for single-ply construction. Double nailing is not needed because the fasteners used on a two-ply application will produce a firmly fastened system. The base ply should be applied with long edges perpendicular to framing members. End joints may occur on or between framing members. Face-ply joints, however, should occur over framing and be offset from base ply joints. If the base ply is foil backed board, apply the foil side against framing.

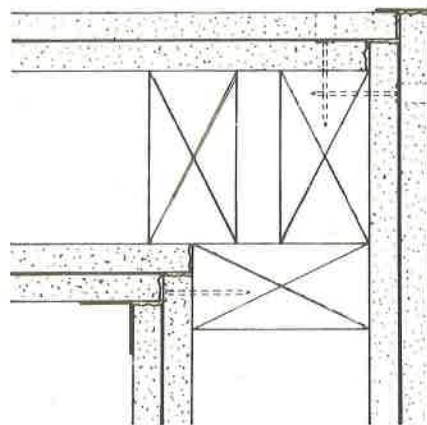

Fig. 36 Floating angle construction for multi-ply systems has overlapping side of base ply only nailed at interior corner.

### Base ply walls

The base ply should be applied with the long edges parallel with the framing members. When predecorated face panels are to be used, the base ply should be applied perpendicular to the framing. At inside corners, it is recommended that only the overlapping base board end be nailed or screwed and that fasteners be omitted from the face ply. The floating corner treatment is better able to resist structural stresses. (Fig. 36)

Staples used to fasten base plies should be driven with the crown perpendicular to the edges of the board. Where edges fall over supports, staples should be driven parallel with the edges. (Fig. 37)

Crowns of driven staples should bear tightly against the board without breaking the face paper.

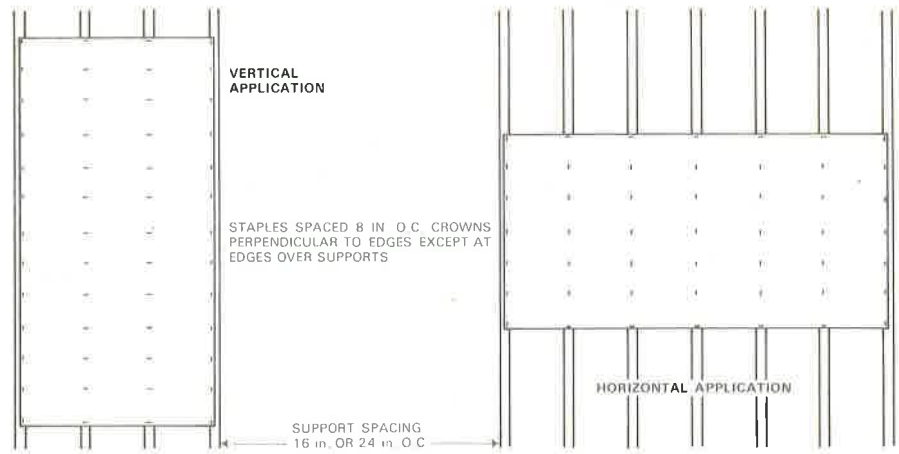

Fig. 37 Staples are driven with crowns perpendicular to gypsum board edges except where edges fall along supporting members.

## METAL FRAMING OR FURRING

### Base Ply Attachment

Base-ply gypsum board is normally attached to metal framing and furring with screws at least 5/16 in. longer than the thickness of the board. Application may be either perpendicular or parallel. In perpendicular application where no adhesive is used between plies the base ply should be fastened with a single screw into each stud or furring channel at the board edges and with one screw at the middle of the board at each stud or channel.

In parallel application with no adhesive between plies, the base ply is fastened with screws 12 in. o.c. along the edges of the board and 24 in. o.c. in each stud in the field of the board.

When the base ply is to be attached either perpendicular or parallel to metal framing 16 in. o.c. and with adhesive between the plies, screw spacing should be 12 in. o.c. for ceilings and 16 in. o.c. for walls. Maximum screw spacing on metal framing at 24 in. o.c. is 12 in. o.c. for both walls and ceilings.

### Face Ply Attachment

The joints in the face ply should be offset at least 10 inches from joints in the base ply. Gypsum board can be

applied to framing either perpendicularly or parallel, whichever results in the least waste of materials. Perpendicular application is preferred on walls since it usually results in fewer joints. Predecorated board is normally installed parallel and does not require joint treatment. Some systems are designed to utilize decorative battens over the joints. When the face ply is attached with mechanical fasteners and with no adhesive between plies, the maximum spacing and minimum penetration recommended for screws should be the same as for single

ply application. These are given in Chapter III under "Screw Attachment."

### Adhesive Attachment

Typical multi-ply construction may employ sheet lamination, strip lamination, or spot lamination to attach the face-ply to the base-ply.

Sheet lamination involves covering the entire back of the face-ply with laminating adhesive using a notched spreader, box spreader, or other suitable tool (Fig. 38). The size and spacing of the notches are determined by the type of adhesive being used. The gypsum board should be erected using



Fig. 38 Notched spreaders are used to apply adhesive for sheet lamination.

moderate pressure, and any adhesive squeezed out at the joints should be promptly removed.

Strip and spot lamination are preferred to sheet lamination in sound rated partitions. In strip lamination, adhesive is applied in ribbons with a special spreader. The ribbons are normally spaced 16 in. to 24 in. o.c. (Fig. 39). In spot lamination, spots of adhesive are brushed or daubed on in a regular pattern.

### Supplemental fasteners

In order to assure satisfactory adhesive bond it is necessary to hold the face ply firmly against the base ply with supplemental fasteners, shoring or bracing while the adhesive is setting. Generally, mechanical fasteners are applied in the field of each

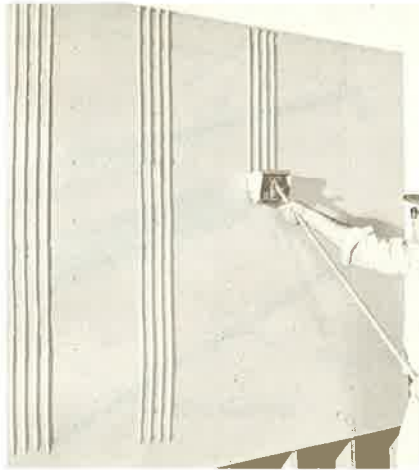

Fig. 39 Notched spreaders may also be used after base layer of board has been installed.

laminated face ply in ceiling applications. On side walls these fasteners can be placed at the perimeter of the board where

they will be concealed by joint treatment or trim. It should be remembered that in fire rated assemblies the specific fastener spacing is given for the particular assembly tested and may not be related to whether or not adhesive is used between the plies. Fastener spacing details in fire rated assemblies are available from the sponsor of the test and, in many cases from the Gypsum Association. In sound-rated partitions where fire resistance is not a consideration, an acceptable practice is to attach the face ply vertically over sound insulation board or backing board with permanent mechanical fasteners in the board ends. Intermediate fasteners are omitted and panels temporarily braced until the adhesive has developed sufficient bond strength.

## SELF-SUPPORTING GYPSUM PARTITIONS

These are nonload-bearing, non-combustible, multi-ply partitions. They can be fabricated at the job site, almost entirely from gypsum board. Inner plies are gypsum studs formed from gypsum board or sheets with the face plies laminated to them. Unlike the framed ceiling and wall assemblies which depend on wood, metal or other construction to support the surface finish, gypsum partitions are entirely self-supporting, and they require only floor and ceiling runners (tracks) to stabilize the partition. Runners (tracks) should be attached securely to ceilings and floors with fasteners spaced not over 24 in. o.c.

Self-supporting gypsum partitions are classified as:

- semi-solid*, utilizing gypsum studs between face plies, and
- solid* with a coreboard inner ply.

All gypsum board components such as studs, coreboard, backing board, wallboard, and pre-decorated board are installed vertically.

### Semi-Solid Partitions

Semi-solid partitions provide vertical interior passages for

mechanical and electrical services. They consist of single or two-ply faces of gypsum board separated by vertical gypsum studs, 6 in. wide and preferably not less than 1-5/8 in. thick.<sup>1</sup> The panels are set vertically in place (Fig. 40). In single-faced partitions, the face ply is attached directly to the studs. Partitions with two-ply faces consist of gypsum studs, a backing-board base ply and a gypsum board face ply.

Semi-solid walls may be pre-laminated or laminated in place. Gypsum studs, cut 6 in. shorter than the wallboard, are laminated to the face ply on one side of the partition. Edges of door and window openings should be reinforced with wood or steel.

Adhesive is spread on the erected base ply or on the studs, keeping the adhesive 1 in. from the stud edges. The stud is then pressed in place. The stud reinforced panels are secured to wood or metal runners at top and bottom with appropriate drywall screws spaced 12 in. o.c.

<sup>1</sup> If one inch thick studs are used care must be taken to assure that proper electrical outlet boxes are used. Outlet boxes must not be permitted to extend through an assembly.

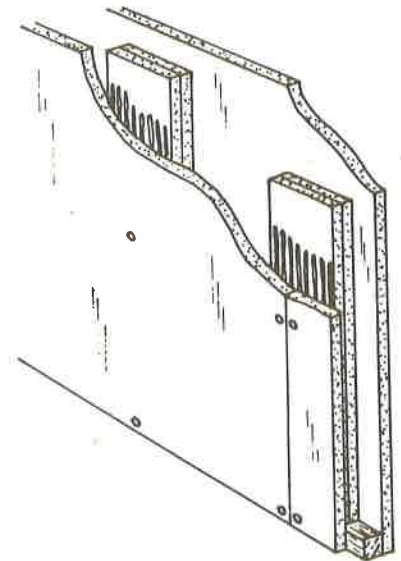

Fig. 40 Semi-solid gypsum wallboard.

Adhesive is then spread on the studs attached to the erected panels, and facing panels are installed over the studs and attached to the runners with screws spaced 12 in. o.c. Adequate bond to the studs is assured by 1-1/2 in. Type G drywall screws placed along each stud beginning 12 in. from the top and bottom and spaced not more than 36 in. o.c.

A rapid method for adhering studs to panels is shown in Fig. 41. After this procedure is carried out, panels with studs

attached are erected with adhesive spread on the exposed face of the studs. The erected panel edges are kept in contact with the studs by supplemental fasteners while the adhesive develops bond.

For partitions with two-ply faces, the studs and base plies are assembled and installed as previously described. The face plies are sheet-laminated as described for two-ply supported partitions using supplemental drywall screws. Screw spacing for fire rated partitions should be in accordance with manufacturer's recommendations or Gypsum Association literature.

Separated stud construction to improve sound isolation qualities can be provided in either single or two-ply partitions. Installation is essentially the same as for regular gypsum stud partitions, but twice as many studs are required. These are spaced 12 in. o.c. and staggered on opposite sides of the partition.

### Solid Partitions

Solid gypsum partitions have gypsum board faces laminated to each side of a coreboard. Vertical joints in the face ply should be offset at least 3 in. from joints in the coreboard. The face ply typically is attached by sheet lamination with supplemental drywall screws. Double and triple solid partitions separated by air spaces are shown in Figs. 42 and 43.

1/2" OR 5/8" x 48" CEILING HEIGHT GYPSUM BOARD

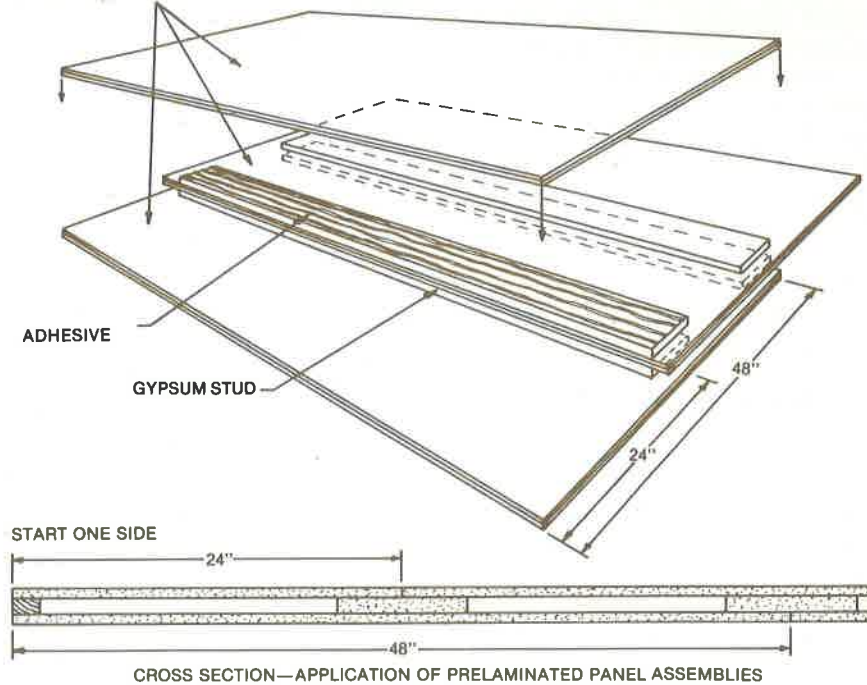

Fig. 41. The following steps result in an efficient method of attaching gypsum studs to face panels for semi-solid partitions.

- STEP 1**-Place two pieces (one bundle) of face layers (plain or predecorated gypsum board) with finish surfaces together on a smooth, level surface;
- STEP 2**-Spread adhesive on one side each of two gypsum studs, using a spreader;
- STEP 3**-Place one stud adhesive face down, in the middle of the top face sheet about 3 in. from each end;
- STEP 5**-Place a second bundle on top of the gypsum studs with the edge flush with the edge of the uncoated stud, again spread two gypsum studs with adhesive and repeat the procedure until the required number of panels are laminated. Place an extra bundle on the top assembly to provide pressure while the adhesive dries.

The depth of electrical outlet boxes installed in solid partitions should not exceed 1 1/2 in. Outlet

boxes installed in double or triple solid partitions, however, may exceed this dimension.

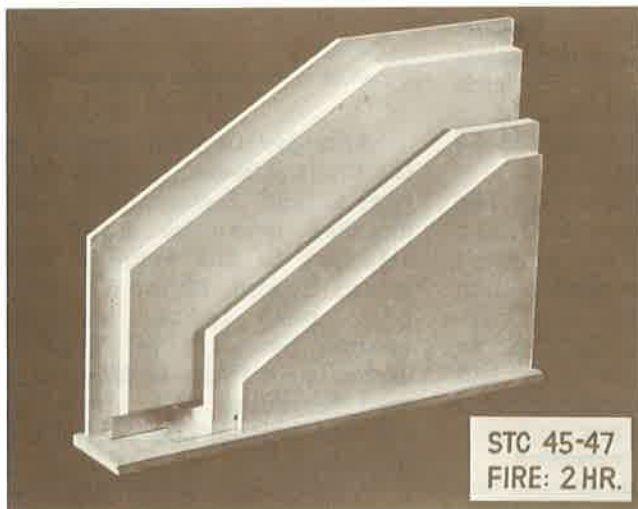

Fig. 42 Double-solid gypsum board partitions have parallel courses attached to two runners separated by an air space. Courses are coreboard faced with wallboard.



Fig. 43 Triple solid gypsum board partitions have three parallel courses and provide superior sound control when a mineral wool or glass fiber blanket is added.

## PREDECORATED COMBUSTIBLE PANELING OVER GYPSUM SUBSTRATE

The addition of gypsum board as a substrate when using predecorated panels provides increased fire resistance and sound control. In new or existing construction a 3/8 in. or 1/2 in. gypsum board substrate is recommended before applying combustible paneling. (Fig. 44)

Data have been developed to show the increased fire resistance, sound control, and impact resistance achieved through the use of gypsum substrate under combustible paneling. Examples are shown in Table V.

### Application

The gypsum board substrate should be attached parallel to

framing using 1-3/8 in. drywall nails, 1 in. drywall screws or a drywall stud adhesive. The spacing of fasteners should be the same as given in Chapter II. The edges of the board should be centered on framing members. The joints need not be taped and finished.

The rigid predecorated panels should be applied using a bead of panel adhesive over each stud and a bead midway between the studs. Joints in the face ply should be staggered from the base ply of gypsum board. Secure the paneling at the top and bottom with 4d finishing nails, 12 in. o.c. and with one nail at mid-height per stud.

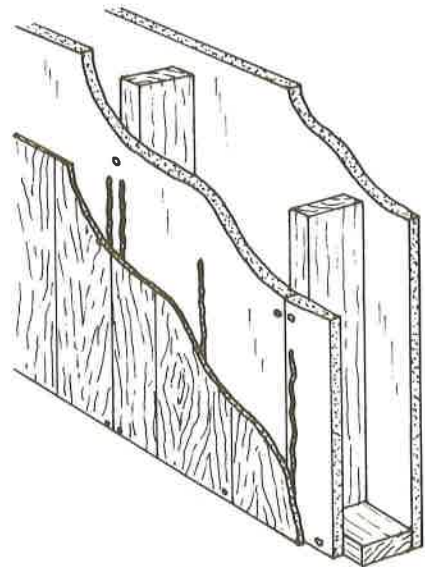

Fig. 44 Predecorated combustible paneling over gypsum substrate.

TABLE V

	1/4" Paneling (No Gypsum Board)	1/4" Paneling With 3/8 in. Gypsum Board	1/4" Paneling With 1/2 in. Gypsum Board
Burn thru Time	8 min.	42 min.	73 min. (plus)
Better Sound Rating	28 STC	40 STC	40 STC
Better Impact Resistance	130 ft-lb	410 ft-lb	410 ft-lb

## RESURFACING EXISTING CONSTRUCTION

Gypsum board may be used to provide a new finish on existing walls and ceilings of wood, plaster, masonry or wall-board. If the existing surface is structurally sound and provides a sufficiently smooth and solid backing without shimming, 1/4 in. gypsum board can be applied with adhesives, nails or screws. Drywall nails shall be of sufficient length to penetrate framing 7/8 in. When power driven screws are to be used the

threaded portion of the screws must penetrate the framing 5/8 in.

Existing surfaces which are too irregular to receive gypsum board directly should be furred and shimmed to provide a suitable fastening surface. Minimum gypsum board thickness for various support spacings and installation methods should be as recommended for new construction over furring. (See Chapter II).<sup>2</sup>

Surface trim for mechanical and electrical equipment such as switch plates, outlet covers, and ventilating grilles should be removed and saved for reinstallation. Electrical boxes should be reset prior to the installation of new gypsum board.

<sup>2</sup> See also Gypsum Association publication *Covering Existing Walls and Ceilings with Gypsum Board Products* (GA-650)

# V JOINT AND FASTENER TREATMENT

After the gypsum board is installed and secured with the proper fasteners, it is necessary to conceal the fasteners and to reinforce and conceal the joints. The fasteners and metal trim are concealed with joint compound to achieve the appearance of a monolithic surface. Reinforcing tape and joint compound are the products recommended for this purpose. They should conform to ASTM C 475 "Standard Specifications for Joint Treatment Materials for Gypsum Wallboard Construction." When applied, the compounds should be of compatible chemical composition with previous successive coats. Do not mix vinyl base, casein base and setting formulations unless recommended by the joint compound manufacturer. During the taping and finishing opera-

tions, adequate and continuous ventilation should be provided to insure proper setting and drying of the taping and finishing compounds. Precreased tape is also available and should be

applied with the pointed side toward the corner or wall and ceiling intersection. Other exposed edges of the gypsum board may require some type of metal casing or appropriate trim.

## JOINT TREATMENT PRODUCTS

Joint tape is designed for use with an adhesive compound to reinforce and finish the joints between adjacent gypsum boards. It may be made of paper, either perforated or unperforated, glass mesh, or other material. Paper tape is available with metal strips which reinforce exterior corners.

Joint reinforcing compounds consist of an adhesive with or

without various additives. They are of three general types:

1. a taping or bedding compound used to adhere the tape to board
2. a finishing or topping compound used especially for finishing
3. an all-purpose compound to be used for both embedding and finishing the joint.

Most joint compounds contain water-soluble dispersible organic adhesives or synthetic resins. These products gain their strength through drying (drying compounds). The loss of water is accompanied by shrinkage which is overcome by several applications of the compound. Each application should be thoroughly dry before the next application is started. Synthetic resin compounds such as "vinyls" will keep longer than the organic water soluble types. Another family of joint compounds gain strength as setting occurs. The set may occur within 30 minutes or take as long as several hours. The quick-set type, having a shorter wet-life, must be used within the prescribed time limit. (Additional coats are possible before complete drying takes place). It is common for setting compounds to be used for embedding the tape and "non-setting" types for the finishing operation.

Joint compounds of the pre-mixed type are also available and in two consistencies: one for hand application and the other for machine application. These compounds should not be allowed to freeze. Finishing operations



Fig. 45 Gypsum board walls and ceilings usually have joints treated with tape and compound to give a smooth, monolithic appearance.

should not take place until the interior temperature has been maintained at a minimum of 50F for a period of at least 24 hours. The temperature should be maintained until the compounds have completely dried.

Care should be taken not to contaminate containers or tools used for different types of joint compounds when mixing or stor-

ing. Even a small quantity of one type of joint compound in the seam of a mixing pail or inside a pump or on a tool can adversely affect the adhesive properties of a full mixture of another type of compound. All equipment *must* be clean. Tools should be disassembled and cleaned after each operation.

## JOINT TREATMENT PROCEDURE

The groove formed by the tapered edges when gypsum boards join should be pre-filled with joint embedding compound. Topping or finishing compound should not be used for embedding tape. Wipe off excess compound that is applied beyond the groove. Center reinforcing tape and press it down into the joint compound. Apply additional joint treatment compound using a 5 or 6 inch finishing knife. Draw the knife along the joint with enough pressure to remove excess compound. To finish, level the compound with the wall surface. There should be sufficient compound under tape for a proper bond but not more than 1/32 in. under the feathered edge.

The initial tape embedding can also be done with a semi-automatic tool that applies the joint compound and tape simultaneously. Allow the compound to dry completely. Drying can take 24 hours or more, depending on temperature and humidity.

After the embedding coat is completely dry, apply a second coat feathered about two inches beyond edges of the first coat. Spot fastener heads and allow to dry. On the end, butt, or field cut board joint where there are no tapered edges, the tape is higher than the board surface and requires a wider application of joint compound feathered out 12 to 16 inches wide.

After the second coat is dry, sand lightly and apply a thin finishing coat to joints and fastener heads. Feather edges to about 6 inches from the center of the joint. The final step prior to decoration is to lightly sand the joints in order to eliminate laps

where joints intersect, and in general, to smooth the surface where necessary. Care should be taken to avoid scuffing the paper surface of the gypsum board as the scuffed areas may show through the decoration. All cut-outs should be back-filled with compound used for taping or finishing so that there is no opening larger than 1/8 in. between the gypsum board and a fixture or receptor.

*Approved protective respirators should be worn when mixing powder or when sanding. Mixing should be done according to the manufacturer's directions.*

## Texturing

It is often desired that the finished surface have a textured appearance. When gypsum board surfaces are to be textured, they must first be coated with a high quality primer paint. Textures with and without aggregate are available to impart surface appearances ranging from light stipples to heavy swirls or simulated acoustical finishes. These are applied by roller, brush or spray machine. The finer textures usually contain perlite or fine vermiculite whereas the coarser types contain coarse vermiculite or expanded and shredded polystyrene.

## Metal Trim and Casings

Figure 52 illustrates some of the more common metal sections used around doors, windows and other openings. They are also used when gypsum board is butted against a different surfacing material.

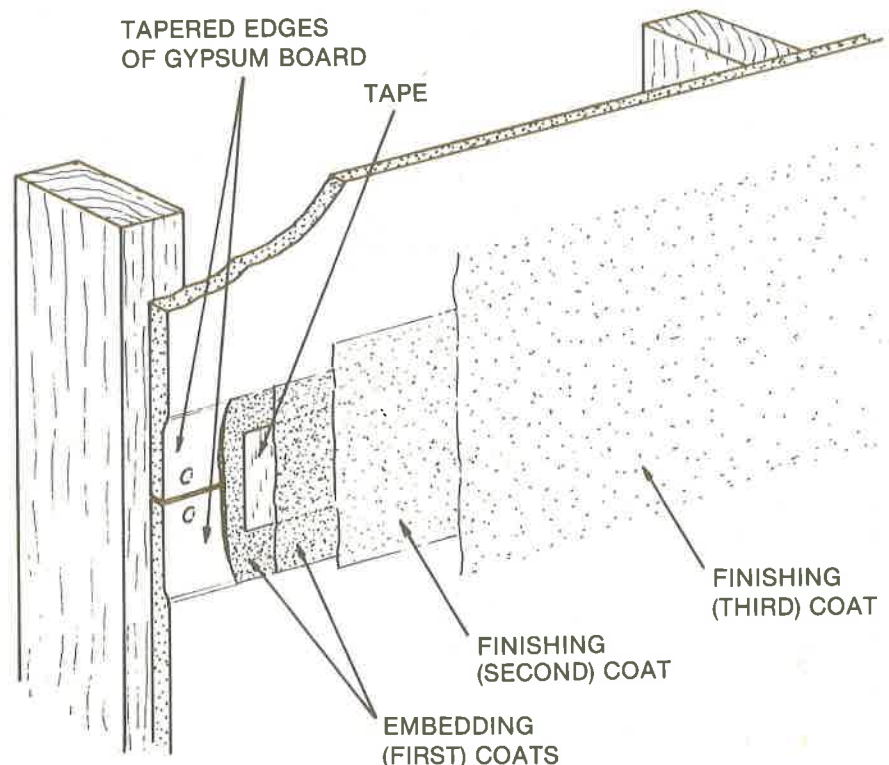

Fig. 46 Reinforcing joints with tape prevents cracks from appearing at filled gypsum board joints. The joint fill and first coat may be joint compound or all purpose compound. The Second and third coats should be finishing compound or all-purpose compound.



Fig. 47 Tape bedding compound being applied to tapered edges of wallboard joint.



Fig. 48 Joint reinforcement tape being applied into bedding compound.



Fig. 49 Joint topping coats are applied.



Fig. 50 Machine application of joint bedding compound and reinforcing tape.



Fig. 51 A variety of textured appearances can be obtained by using a spray machine.

Fig. 52

**METAL TRIM AND CASINGS**

**Cornerbead** — (Numbers indicate width of flanges, i.e. — 118 is 1 1/8 in. wide flange)

- CB — 100 x 100
- CB — 118 x 118
- CB — 114 x 114
- CB — 100 x 114
- CB — PF (Paper flange, stzel corner combination bead)



**"U" Bead** — (Numbers indicate thickness of board to be used, i.e. — 38 is 3/8 in.)

- U-38
- U-12
- U-58
- U-34



**"L" Bead** — (Numbers indicate thickness of board to be used)

- L-38
- L-12
- L-58
- L-34



**"LK" Bead** — (For use with Kerfed jamb)

- LK-B
- LK-S

(B-Bull or round nose)  
(S-Square nose)

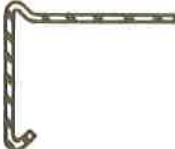

**"LC" Bead** — (Numbers indicate thickness of board to be used)

- LC-38
- LC-12
- LC-58
- LC-34





## PROBLEMS AND REMEDIES

### Nail Pops

Nail popping can be reduced by using the recommended dry-wall nails as shown in figure 23 on page 12. Nails must be properly driven into correctly aligned framing free from excessive moisture. In spite of precautions, nail popping may occur. The remedy is to drive another nail within 2 in. of the popped nail. The defective fastener should be reset using a nail set and the surface then repaired with joint treatment compound.

### Beading or Ridging

Beading or ridging is usually caused by structural movement and results in surface protrusions along the treated joints. Beading can be caused by high humidity. When this condition occurs, it is advisable to wait six months or a complete heating season before repairing. This will allow shrinkage of the framing and settling of the structure to take place. The corrective action is to lightly sand the surface protrusion down to the tape without cutting into it. Cover the sanded surface around the joint with taping compound as wide as necessary to make sure the area on each side is on the same plane. The finished joint can be viewed in a strong sidelight to be sure the condition has been corrected before redecorating.

### Shadowing

Joint and fastener head shadowing (show-through) can be due to any one of several causes. If the joint is crowned (higher than the plane of the board on each side) it will be seen in a low angle light. All joints should be finished in such a manner that the center of the joint is only slightly higher than the plane of the gypsum board surface and finished with a wide, flat, feathered edge. The remedy for a high or crowned joint is to widen the joint out to 14 in. to 16 in. or as necessary.

Another type of shadowing can occur over the fasteners. This is often caused by accumulation of dirt or dust because these areas are colder than the surrounding gypsum board. Condensation can occur and subsequent dust accumulation with dark spots result. The spots can be washed. The preventive procedure is to install adequate insulation to minimize the lower temperatures over the fastener heads.

### Cracking

Movement of the structure can impose severe stresses and cause cracks either at the joint or in the field of the board. Cracks are more prevalent at an archway or over a door since this is usually the weakest point in the

construction. In new construction, it is wise to wait until at least one heating season has passed before repairing or refinishing. The best repair method for cracks over 1/8 in. in width is to tape the crack and finish in the same manner as a conventional joint. It will be necessary to feather the joint out rather wide in order to hide the tape and produce a level surface. Minor cracks can be spackled, sanded and redecorated.

A source of cracking in nonbearing walls of highrise or commercial buildings, is the modern trend toward less rigid structures. Larger deflections in structural members and greater expansion and contraction of exterior columns can impose unexpected loads on nonbearing walls and lead to cracking. Detailed designs for perimeter relief of nonbearing partitions are available to improve this condition. (Fig. 53) One example is the use of relief runners to attach nonbearing walls to ceiling and column members.

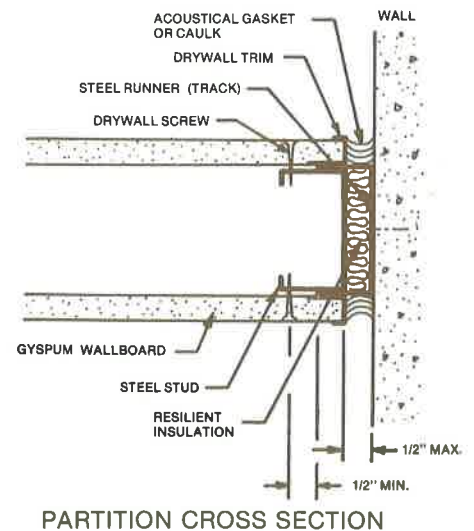
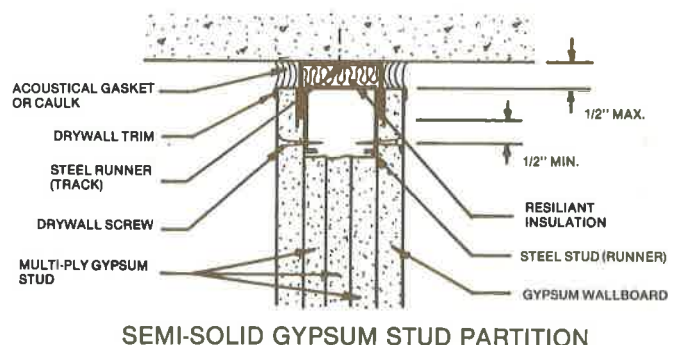
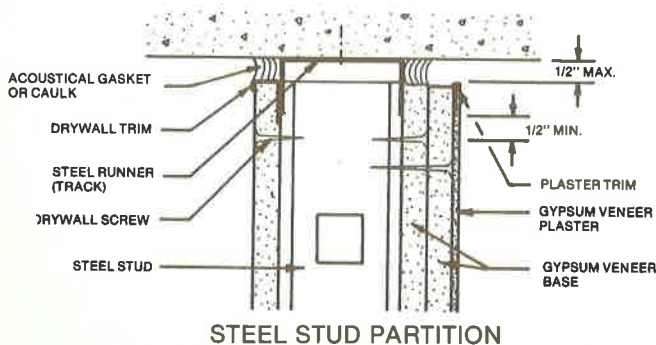

Fig. 53



## VI DECORATING

Gypsum board finishes should be reinspected prior to decorating, particularly at joints and fasteners. Any imperfections should be sanded or repaired. Joint compounds must be thoroughly dry before the decoration is applied.

Gypsum board surfaces can be decorated with paint, paper, textures, fabric or vinyl wall coverings. Before decorating, always seal or prime the surface with a good quality emulsion paint. Color or surface variations are thereby concealed and a more uniform texture for any surface covering is provided. The sealer allows the wall coverings to be removed more easily without marring the surface. Glue-size, shallac and varnish are not suitable as sealers or primers.

Latex paints do not raise the fibers in the face paper as oil base paints do, and therefore are preferred for sealing and priming and may also be used for the finish coat when two more applications are made. Paints may be spray, brush, or roller applied. The final coat can be textured if desired.

### Predecorated Gypsum Board

Patterns or colors on some kinds of predecorated gypsum board may vary slightly from lot to lot. All the board used in a room should be from the same lot, but when this is not possible, the joint between two different lots should be in a corner.

Care should be taken to match the patterns and colors on adjacent pieces of predecorated gypsum board. One procedure is to simply stand the boards in the places they are to occupy. Boards that do not match well are shifted. If joints are to be covered with metal trim, plan the layout of walls and ceilings in advance so that a balanced layout of joints is obtained. Avoid the appearance of two metal trimmed joints close together in a corner. If the stud spacing is not proper to allow an attractive arrangement of joints, furring strips may be necessary so that joint locations may be shifted.

Cut edges that are to be covered with trim (moldings or battens) can be sawed or scored

and snapped the same as regular gypsum board. If cut edge joints are to be exposed, however, the face material should be cut approximately 1 in. wider than the gypsum core. The core should then be snapped and removed from the fabric — not the fabric from the core. The core should be trimmed straight and beveled on the face side under the flap. The overlapping face material is then pulled around the edges and fastened to the back with adhesive after removing any remaining paper in the flap.

**NOTE:** When using adhesives for the application of vinyl covered gypsum board, read and follow the gypsum board manufacturer's instructions. Improperly applied, or incompatible adhesives can damage vinyl finishes.

## VII SPECIAL CONSTRUCTION

Most special constructions which are designed to improve sound, fire, moisture and thermal control depend on gypsum board assemblies built to specifications

designed to accomplish the higher classifications. These include consideration of proper framing techniques, fasteners, caulking, taping and finishing of

joints. In each case, the manufacturer's specific installation recommendations should be closely followed for individual systems.

### SOUND INSULATION CONSTRUCTION

The first essential for airborne sound insulation of any assembly is to close off air leaks and flanking paths. Since noise can travel over, under, or around walls, through windows and doors adjacent to them, through air ducts and through floors and crawl spaces below, these flanking paths must be correctly treated to reduce the transmission of sound. At higher frequencies, hairline cracks and small holes will increase the transmission of sound. This can have a detrimental effect on the overall acoustical performance affecting the Sound Transmission Class (STC), particularly in higher rated assemblies. Where a very high STC performance is needed, air conditioning, heating and ventilating ducts should not be included in the assembly. Failure to observe special construction and design details can destroy the effectiveness of the best assembly.

Improved sound isolation is obtained by:

- Separate framing of the two sides of the wall
- Resilient channel mounting for the gypsum board
- Including sound absorbing materials in the wall cavity
- Using adhesively applied gypsum board of varying thicknesses in multi-layer construction.
- Caulking the perimeter of gypsum board partitions, openings in walls and ceilings, partition-mullion intersections, outlet box openings, etc.
- Locating recessed wall fixtures in different stud cavities.

(Medicine cabinets, electrical, telephone, television and intercom outlets, plumbing, heating and air conditioning ducts should not be installed back to back).

Any opening for such fixtures, piping and electrical outlets should be carefully cut to proper size and caulked. The entire perimeter of sound insulating partitions should be caulked around gypsum board edges to make it airtight as detailed in Figure 54 on pg 30. The caulking should be nonhardening, nonshrinking, nonbleeding, nonstaining, resilient sealant. Sound control sealing must be covered in the specifications, understood by the workmen of all related trades, supervised by the foreman, and inspected carefully as construction progresses.

#### Separated Partitions

A staggered wood stud gypsum partition placed on separate plates will effectively decouple the system and provide an STC of 40-42. The addition of a sound absorbing material between the studs of one partition side can increase the STC as much as 8 points. With 5/8 in. type X gypsum board on each side this assembly has a fire resistance classification of one-hour.

Separated walls without framing can also be constructed using an all-gypsum double solid or a semi-solid partition. Steel or wood runners (track) fastened to floor and ceiling hold the partitions in place.

For the attachment of kitchen

cabinets, lavatories, ceramic tile, medicine cabinets and other fixtures, a staggered stud wall rather than a resiliently mounted wall is recommended. The added weight and fastenings may "short circuit" the construction acoustically.

#### Resilient Mounting

Resilient attachments, acting as "shock absorbers", reduce passage of sound through the wall or ceiling and increase the STC rating. Further STC increases can result from more complex construction methods using multiple layers of gypsum board and building insulation in the wall cavities.

#### Walls

Resilient furring channels are attached with the nailing flange down and at right angles to the wood studs (Figure 55c). Drive 1-1/4 in. Type W screws or 6d coated nails through the pre-punched holes in channel flange. With extremely hard lumber, 7/8 in. or 1 in. Type S screws may be used. Locate channels 24 in. from the floor, within 6 in. of the ceiling line and no more than 24 in. o.c. Extend channels into all corners and fasten to corner framing. Attach 1/2 in. by 3 in. wide continuous gypsum board filler strips to the bottom plate at floor line. Channels should be spliced directly over studs by overlapping ends and fastening both flanges to the support.

Apply gypsum board horizontally with long dimension

**"NORMAL" CONSTRUCTION ...**

Arrows show flanking paths

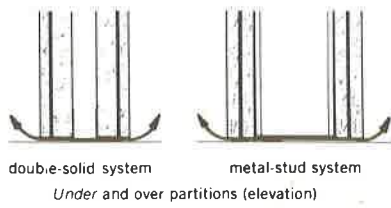

**"SELECT" CONSTRUCTION ...**

Caulking of relief detail at perimeter of partition to prevent sound leakage

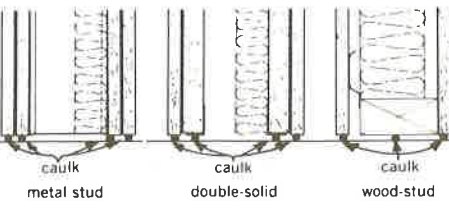

**"PRE-DESIGN" CONSTRUCTION ...**

Simulating laboratory conditions

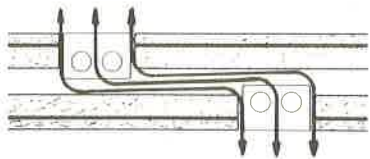
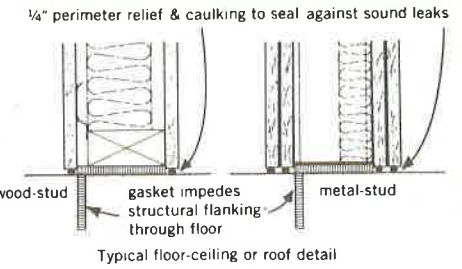

Through partitions – openings, outlet boxes (plan)



Caulking of openings through partitions

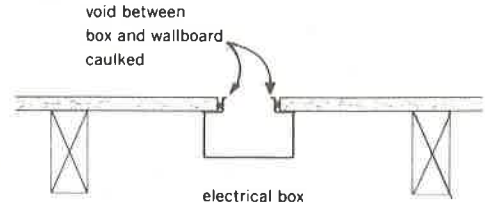

Outlet box detail

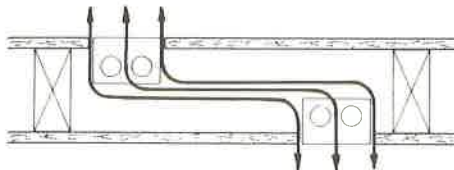

Through partitions – openings, outlet boxes (plan)

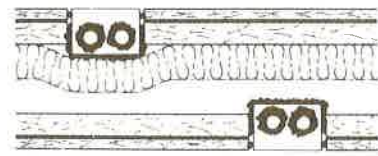

Caulking of openings through partitions

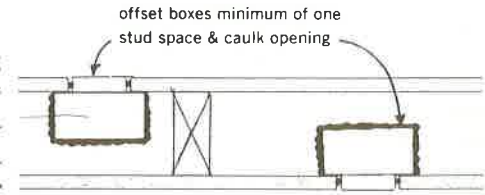

Outlet box detail

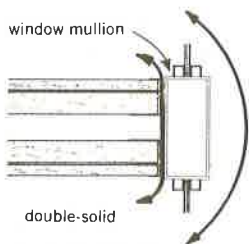

Around – flanking partition ends (plan)

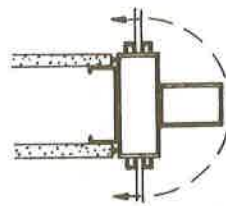

Typical partition-mullion intersection

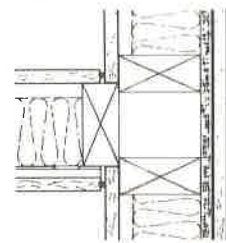

Intersection with exterior wall



Around – flanking partition ends (plan)

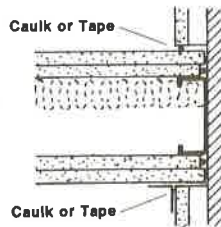

Intersection with interior wall

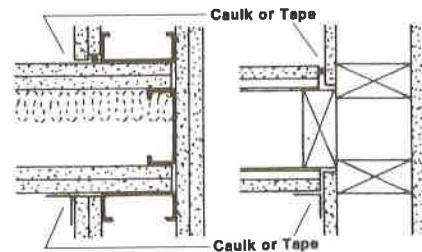

Typical partition intersections

Fig. 54 Sound isolating techniques improve the sound transmission class (STC) and noise reduction of gypsum walls.

parallel to channels using 1 in. Type S screws spaced 12 in. o.c. along channels. Abutting edges of boards should be centered over channel flange and securely fastened.

## Ceilings

Resilient furring channels are attached at right angles to wood joists in ceilings using 1-1/4 in. Type W or Type S screws or 6d coated nails 1 7/8 in. long. Locate channels within 6 in. of the wall-ceiling intersection and no more than 24 in. o.c. for joists spaced 24 in. o.c. maximum. Extend the channel into all corners and fasten to corner framing. Channels should be spliced directly under joists by nesting channel and screwing through both flanges to support.

Apply the gypsum board with Type S screws spaced 12 in. o.c. in the field and along abutting ends. Apply the long dimension of the board at right angles to the channels with end joints neatly fitted and staggered in alternate rows. A minimum 21 in. cut length of resilient channel should be used for back blocking butt joints not falling on furring members.

## Sound Insulating Materials

- Mineral (including glass) fiber blankets and batts used in wood stud assemblies.
- Semi-rigid mineral or glass fiber blankets for use with metal studs and laminated gypsum partitions.
- Mineral (including glass) fiber board.
- Gypsum core sound insulating board used behind gypsum board applied adhesively or mechanically fastened.
- Rigid plastic foam board used in exterior wall furring systems.
- Lead or other special shielding material.

Mineral wool or glass fiber insulating batts and blankets may be used in assembly cavities to absorb airborne sound within the cavity. They should be placed in the cavity and carefully fitted behind electrical outlets, around blocking and fixtures and

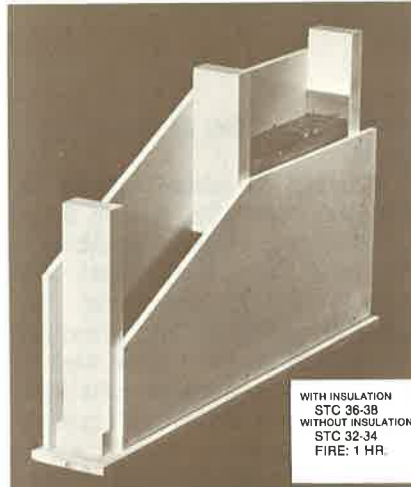

Fig. 55a Adding sound absorbing insulation increases the STC four points in this wall.

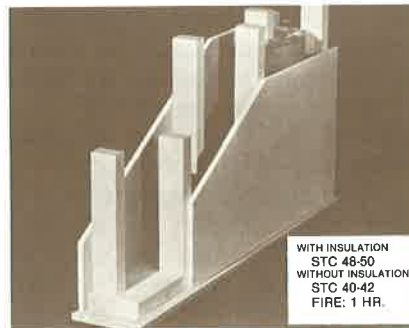

Fig. 55b Staggered studs provide partially separated framing for wall surfaces and increase STC about eight points from wall in Fig. 56a. Addition of sound absorbing material can further raise STC to the 48-50 range.

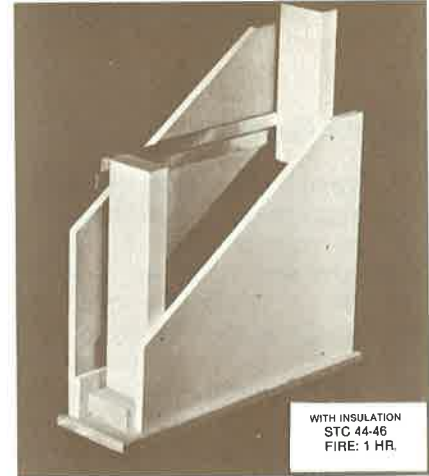

Fig. 55c Resilient mounting of gypsum board surfaces raises STC about 12 points above that of wall in Fig. 56a.

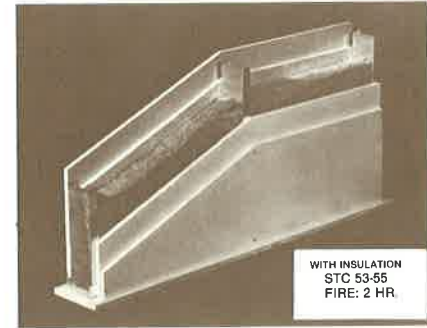

Fig. 55d Two-ply construction increases the weight of the wall surfaces and helps provide higher sound resistance of wall with STC of 53-55 obtainable.

around cutouts necessary for plumbing lines.

Insulating batts and blankets may be faced with paper or other vapor barrier and may have flanges or be unfaced friction fitted. They are installed by stapling or fitting to the inside surfaces of studs (Figure 56). Avoid fastening to the face of studs in order to assure good board-to-stud contact. In metal framed and in laminated all-gypsum board partitions, the blankets are attached to the back of the gypsum board. Batts and blankets without facings are used in noncombustible construction and are installed by friction fitting within the stud space.

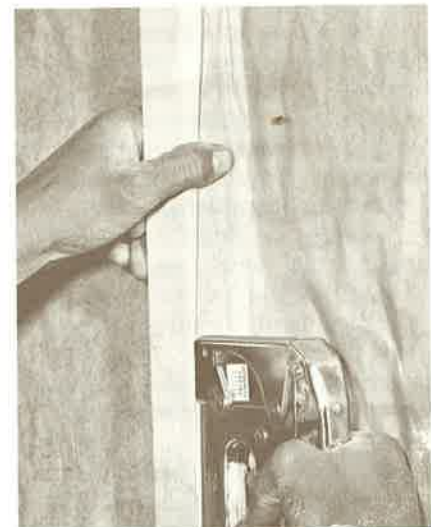

Fig. 56 Paper-faced insulating blankets should have flanges stapled to inside surface of studs. Stud faces to receive gypsum board should be left free.

# RIGID PLASTIC FOAM INSULATION

## General Procedures

Gypsum board may be applied over rigid plastic foam insulation on the interior side of exterior masonry and concrete walls to provide a finished wall and protect the insulation from early exposure to fire originating within the building. Additionally, these systems provide high insulation values needed for energy conservation.

In new construction or remodeling, these systems can be installed with as little as 1 in. dimension from inside face of framing or masonry to face of gypsum board (1/2 in. insulation and 1/2 in. type X gypsum board).

Gypsum board applied over rigid plastic foam insulation in the manner described in this section may not necessarily provide finish ratings required by local building codes.

Many building codes require a minimum fire protection for rigid foam on interior surfaces equal to that provided by 1/2 inch type X gypsum board when tested over wood framing. Flammability characteristics of rigid foam insulation products vary widely, and the manufacturer's literature should be reviewed.

## Mechanical Application

In applying gypsum board over rigid foam insulation, the entire insulated wall surface should be protected with the gypsum board, including the surface above ceilings and in closed, unoccupied spaces.

Single or double-ply, 1/2 in. or 5/8 in. thick, gypsum wallboard should be screw-attached to steel wall furring members attached to the masonry in accordance with the insulation manufacturer's directions, or with nails directly into wood framing (See fig. 27 and 28.)

Furring members should be designed to minimize thermal transfer through the member and to provide a 1-1/4 in. minimum width face or flange for

screw application of the gypsum board.

Furring members should be installed vertically, spaced 24 in. o.c. Blocking or other backing as required for attachment and support of fixtures and furnishings should be provided. Furring members should also be attached at floor-wall and wall-ceiling angles (or at the termination of gypsum board above suspended ceilings), and around door, window and other openings.

Single-ply gypsum board should be applied vertically with the long edges of the board located over furring members. Gypsum boards should be placed so that end joints are avoided.

Fastener spacing should be as required for single ply application over framing or furring.

In double-ply application, the base ply should be applied vertically. The face ply may be applied either vertically or horizontally. Edge joints of vertically applied face ply and end joints of horizontally applied face ply should be offset at least one furring member space from base ply edge joints.

Fastener spacing should be as required for two-ply application over framing or furring (See Table IV).

In all wallboard applications mechanical fasteners should be of such length that they do not penetrate completely to the masonry or concrete. In single layer application, all joints between gypsum boards should be reinforced with tape and, in addition, gypsum wallboard joints should be finished with joint compound. In two-ply application the face layer joints may be concealed or left exposed. Vinyl faced gypsum wallboard face layers should not be adhesively applied over a rigid foam insulated wall.

## Control Joints

Control joints should be installed in gypsum board systems wherever expansion or control joints occur in the base exterior wall and not more than 30 ft. o.c. in long wall furring runs. Wall or partition height door or window frames may be considered control joints. The gypsum board should be isolated from structural elements (columns, beams, load-bearing interior walls, etc.) and from dissimilar wall or ceiling finishes by control joints, metal trim or other means.

## MOISTURE RESISTANT CONSTRUCTION

### Exterior Ceiling Soffit Construction

Gypsum board is suitable for commercial use as ceilings for covered walkways and malls, large canopies and parking areas, and for residential use in open porches, breezeways, carports and exterior soffits. These areas must be horizontal or sloping downward away from the build-

ing. Framing should be no more than 16 in. o.c. for 1/2 in. thick gypsum board, nor more than 24 in. o.c. for 5/8 in. board. Suitable facias and moldings should be provided around the perimeter to protect the board from direct exposure to water. Unless protected by metal or other water stops, the edges of the board should be placed not less than 1/4 in. away from abutting vertical surfaces, (Figure 57).

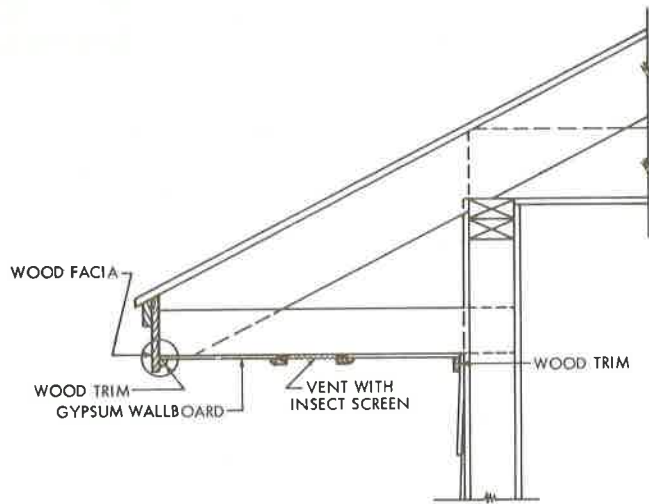

## FRAME WALL

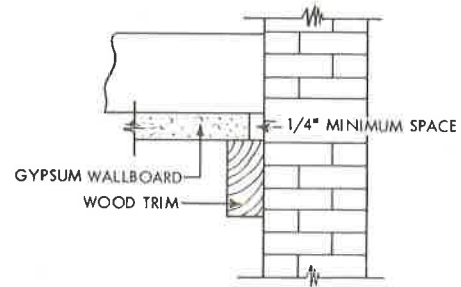

## MASONRY WALL

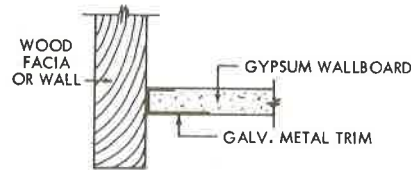
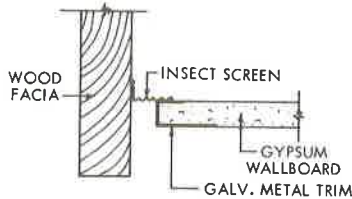

## ALTERNATE FACIA DETAILS

Fig. 57 Gypsum board should be protected from wetting in outdoor locations by fascia boards with drip edges. Gypsum board edges should be separated from possible dampness by metal trim or by a 1/4 in. space. Spaces enclosed by gypsum board must be adequately vented.

The exposed surfaces of the gypsum board and metal trim should be sealed with two coats of exterior paint.

Where the area above opens to an attic space over habitable rooms, the attic space should be vented to the outside. Where the gypsum board is applied directly to joists or rafters, vents are required at each end of each joist space. Vents should be screened and be a minimum 2 in. by the full width between the joists and should be located within 6 in. of the outer edge of eaves. The standard application and finishing methods for ceilings in Chapters II and V should be followed. The placement of vents above window openings should be avoided.

### Bath-Shower Areas

Water resistant gypsum backing board complying with standard ASTM C630 is recommended for use in bathrooms, laundries, kitchens, utility rooms

and other areas subject to moisture. It is used as a base for the adhesive application of ceramic and plastic tile and plastic finished wall panels in shower and tub enclosures. Special adhesives are manufactured for this purpose. Water resistant gypsum board subjected to moisture should not be foil backed, or applied directly over a vapor barrier, and is not recommended for use in areas subject to extreme exposure to moisture, such as saunas, steam rooms and gang shower rooms.<sup>1</sup>

Water resistant gypsum backing board should be applied horizontally with the factory bound edge spaced a minimum of 1/4 in. above the lip of the shower pan or tub. Shower pans, or tubs should be installed prior to the installation of the gypsum board. Shower pans should have an upstanding lip or flange a minimum of 1 in. higher than the water dam or threshold contained in the entry way to the shower. It is recommended that

the tub be supported at the walls on metal hangers or vertical blocking nailed to the studs. If necessary, the board should be furred away from the framing members so that the lip of the tub (Fig. 58a) or the upstanding leg of the pan (Fig 58b) will be on the same plane with the face of the board.

An additional gypsum board extending the full height from floor to ceiling is required for a fire or sound rated construction. (Figure 59).

Suitable blocking should be provided approximately 1 in. above the top of tub or pan.

<sup>1</sup> Ceramic wall tile application to gypsum board should meet American National Standard Specifications for Installation of Ceramic Tile With Water-Resistant Organic Adhesives, ANSI A108.4-1968. The adhesives used should meet the specifications of the American National Standard for Organic Adhesives for Installation of Ceramic Tile, ANSI A136.1-1967. (Rev. 1972)

Between-stud blocking should be placed behind the horizontal joint of the gypsum board above the tub or shower pan. Studs at least 3-1/2 in. deep should be used 16 in. o.c. for a ceramic tile application. Appropriate blocking, headers or supports should be provided for tub, plumbing fixtures, and to receive soap dishes, grab bars, towel racks and similar items as required.

Water-resistant gypsum backing board should be attached with nails or screws spaced not more than 8 in. o.c. When ceramic tile more than 3/8 in. thick is to be applied, the nail or

screw spacing should not exceed 4 in. o.c. When it is necessary that joints between adjoining pieces of gypsum board, (including those at all angle intersections) and nail heads under areas to receive tile or wall panels be treated with joint compound and tape, either use waterproof, non-hardening caulking compound or seal treated joints and nail heads with a compatible sealer prior to tile installation.)

NOTE: The caulking compound or the sealer must be compatible for use with the adhesive to be used for application of the tile.

Interior angles should be reinforced with supports to provide rigid corners. The cut edges and openings around pipes and fixtures should be caulked flush with waterproof, nonhardening caulking compound or adhesive complying with American National Standard for Organic Adhesives for Installation of Ceramic Tile, Type I (ANSI A 136.1). Directions of the manufacturer of the tile, wall panel or other surfacing material should be followed.

The surfacing material should be applied down to the top surface or edge of the finished shower floor, return, or tub and installed to overlap the top lip of receptor, sub-pan or tub and should completely cover the following areas: (Fig. 60)

- over tubs without showerheads - 6 in. above the rim of the tub,
- over tubs with showerheads - a minimum of 5 ft. above the rim or 6 in. above the height of the showerhead, whichever is higher,

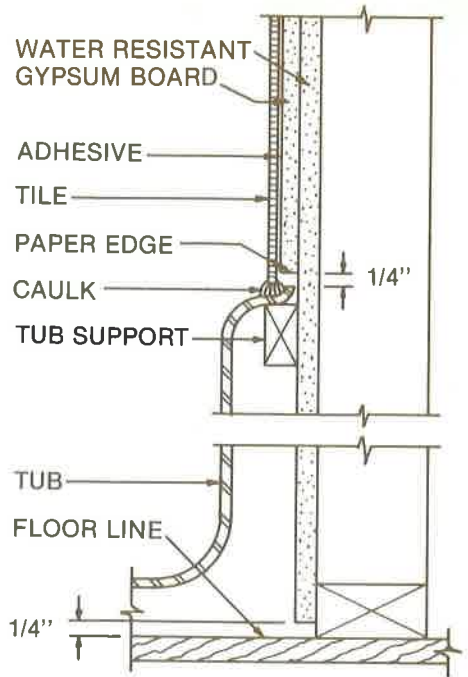

Fig. 59 Details show installation of wall tile on gypsum board around tubs and showers. The gypsum board must be separated from the tub, receptor, or pan by at least 1/4 in. gap to prevent moisture wicking.

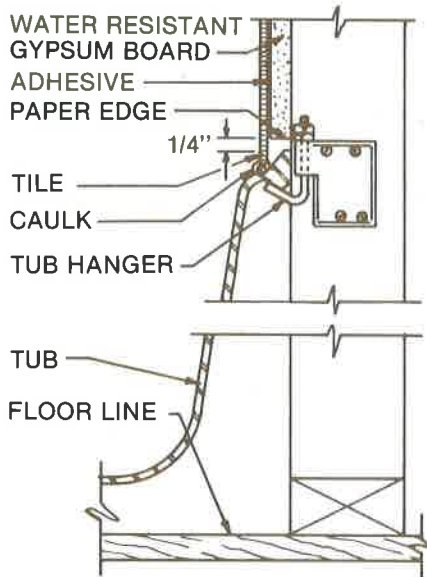

Fig. 58a

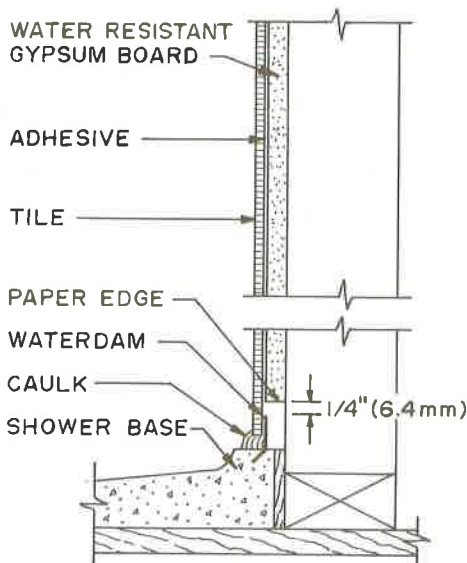

Fig. 58b

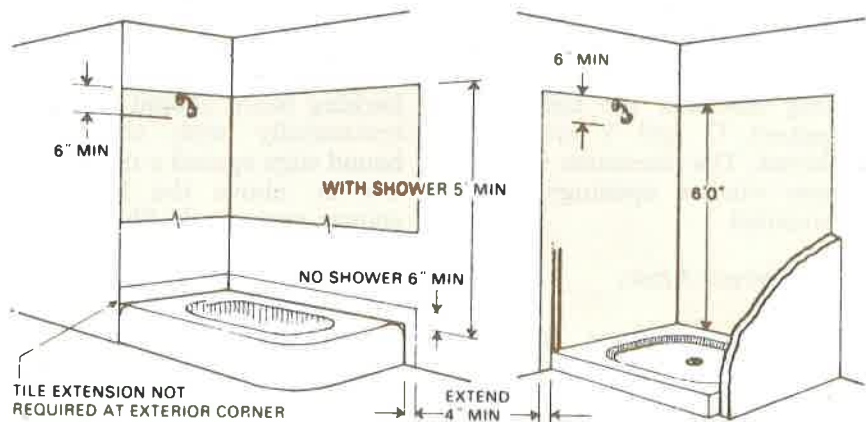

Fig. 60 Tile in baths and showers should be brought up to the levels shown.

- shower stalls - a minimum of 6 ft. above the shower dam or 6 in. above the showerhead, whichever is higher,
- beyond the external face of the tub or receptor - a distance of at least 4 in. and to the full specified height,
- all gypsum board walls with window sills or jambs in shower or tub enclosures - to the full specified height.

For plastic finished wall panels, the recommendation of the manufacturer should be followed.



## ELECTRIC RADIANT HEATING SYSTEMS

Packaged electric panel heating systems are commercially available utilizing gypsum board as the base material and can be installed as a complete system in new or existing structures. Also on-site systems can be fabricated in-place utilizing gypsum backing board, electric heating cable, a filler material and a face ply of gypsum board. Radiant heating systems should not be operated with wire temperature exceeding 125F unless a higher temperature is specifically recommended by the gypsum board manufacturer.

Proper insulation adds to the efficiency of electric radiant panel heating systems. Unfaced, friction-fitted mineral wool or glass fiber insulating batts may be used in properly ventilated areas above the radiant heated ceiling. Blown-in insulation may also be utilized. Interior walls and foundation walls should also be efficiently insulated. Local electric utilities can offer specific recommendations.

It is recommended that a base layer of gypsum board at least 1/2 in. thick be attached perpendicularly to ceiling supports with nails 7 in. o.c. or with screws spaced 12 in. o.c. Taping of joints is not required. Electric heating cables should be securely attached to the backing board in accordance with the recommendations of the cable manufacturer and the requirements of the National Electrical Code. Cables should be parallel to and between framing members with at least 1-1/4 in. clearance from center of framing member on each side so that at least a 2-1/2 in. wide

unobstructed strip is provided under each framing member. Cables should cross framing members only at ends of ceiling 4 to 6 in. from the wall. There should be at least a 4 in. space clear of cables completely around the perimeter of each ceiling. Cables should be kept at least 8 in. clear of all openings such as light fixtures. (Fig. 61)

All inspections and testing of the heating system should be completed before the application of the filler material.

The heating cable must be completely embedded with a nonshrinking, noninsulating filler applied 1/4 in. thick, leveled and finished to a smooth surface. The filler material should be allowed to dry before the face board is installed.

To prevent striking heating cables where they cross framing

members, attach the face layer of gypsum board (no thicker than 1/2 in.) with nails or screws 8 to 10 inches away from the wall around the perimeter of the ceiling. The spacing of fasteners should be the same as the base layer application, allowing 7/8 in. penetration into the framing members for nails and 5/8 in. for screws. The joints and fastener heads should be finished as detailed in Chapter V. A minimum of one week with carefully controlled drying conditions should be provided. Up to two weeks of drying time in cold conditions may be necessary before operating the heating system.

Decoration of the finished work, including sealing, should not proceed until the heating system has been tested a minimum of 24 hours. The heating system should then be turned off and allowed to cool before decorating.

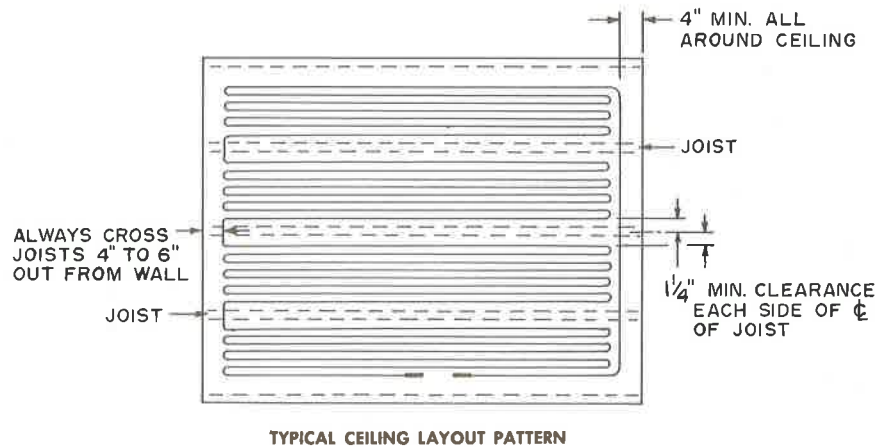

Fig. 61 Electrical heating panel is formed from cable fastened to gypsum board covered with a filling material.

## GYPSUM ASSOCIATION MEMBERSHIP LIST

### AMERICAN GYPSUM COMPANY

P.O. Box 6345  
Albuquerque, New Mexico 87107

### THE CELOTEX CORPORATION

A Jim Walter Company  
P.O. Box 22602  
Tampa, Florida 33622

### DOMTAR CONSTRUCTION MATERIALS

Division of Domtar Inc.  
P.O. Box 6138  
Montreal, Quebec H3C 3K4  
Canada

### THE FLINTKOTE COMPANY

Building Materials Marketing Division  
P.O. Box 800  
Dallas Texas 75221

### GEORGIA-PACIFIC CORPORATION

900 S.W. Fifth Avenue  
Portland, Oregon 97204

### GOLD BOND BUILDING PRODUCTS

A National Gypsum Division  
2001 Rexford Road  
Charlotte, North Carolina 28211

### GRAND RAPIDS GYPSUM COMPANY

P.O. Box 2475  
Grand Rapids, Michigan 49501

### NORWEST GYPSUM

5931 East Marginal Way South  
Seattle, Washington 98134

### PABCO GYPSUM

Division of Pacific Coast  
Building Products, Inc.  
37851 Cherry Street  
P.O. Box 405  
Newark, California 94560

### REPUBLIC GYPSUM COMPANY

P.O. Box 750  
Dallas, Texas 75221

### TEMPLE-EASTEX INCORPORATED

P.O. Drawer N  
Diboll, Texas 75941

### THREE RIVERS GYPSUM, INC

2432 Walnut Ridge Street  
Dallas, Texas 75229

### TRUROC GYPSUM PRODUCTS LTD

Suite 901, College Plaza  
8215 - 112th Street  
Edmonton, Alberta T6G 2C8  
Canada

### UNITED STATES GYPSUM COMPANY

101 South Wacker Drive  
Chicago, Illinois 60606

### WESTERN GYPSUM CO

A Division of Dry Wall  
Supply, Inc.  
P.O. Box 2636  
Santa Fe, New Mexico 87501

### WESTROC INDUSTRIES LIMITED

2650 Lakeshore Highway  
Mississauga, Ontario L5J 1K4  
Canada



**GYPSUM  
ASSOCIATION**

1603 Orrington Avenue  
Evanston, Illinois 60201

1800 North Highland Avenue  
Hollywood, California 90028

1120 Connecticut Avenue, N.W.  
Washington, D.C. 20036



# USING GYPSUM BOARD

## FOR WALLS AND CEILING

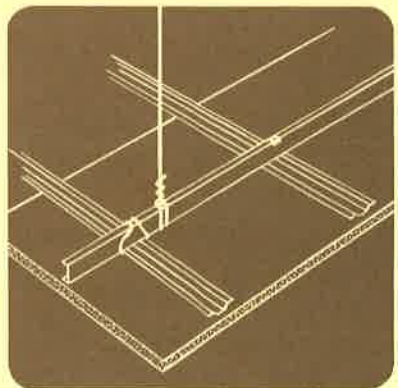
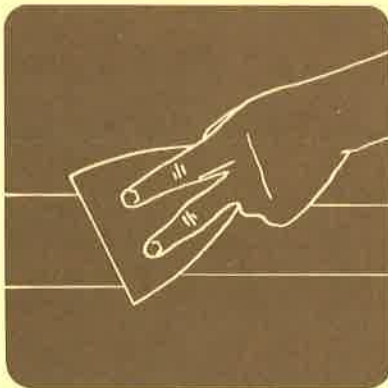
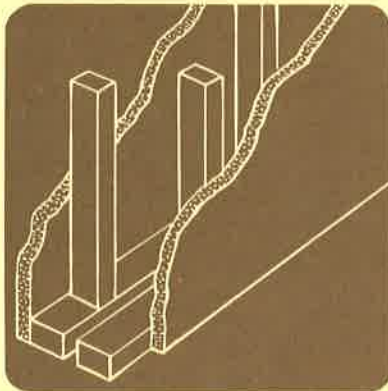

**GYPSUM  
ASSOCIATION**

1603 Orrington Avenue,  
Evanston, Illinois 60201